



CONNECTTM

502USB

802USB

1002FX / USB

1202FX / USB

OPERATING MANUAL AND USER GUIDE



www.wharfedalepro.com

TABLE OF CONTENTS

IMPORTANT WARNINGS & SAFETY INSTRUCTIONS	2
INTRODUCTION	4
ABOUT THE CONNECT MIXERS	4
FEATURES	5
USB INTERFACE	6
FX INTERFACE	6
WALKTHROUGH—CONNECT 502USB	7
WALKTHROUGH—CONNECT 802USB	8
WALKTHROUGH—CONNECT 1002FX/USB (also for 1202)	9
WALKTHROUGH—REAR PANEL	10
WIRING DIAGRAM	10
DIMENSIONAL DRAWING	11
BLOCK DIAGRAM	13
SPECIFICATIONS	17



IMPORTANT WARNINGS & SAFETY INSTRUCTIONS

1. Read these instructions.
2. Follow all instructions.
3. Keep these instructions.
4. Heed all warnings.
5. Do not use this apparatus near water.
6. Clean only with a dry cloth.
7. Do not block any ventilation openings. Install in accordance with the manufacturer's instructions.
8. Do not install near any heat sources such as radiators, heat registers, stoves, or other apparatus (including amplifiers) that produce heat.
9. Do not defeat the safety purpose of the polarised or grounding-type plug. A polarised plug has two blades with one wider than the other. A grounding plug has two blades and a third grounding prong. The wide blade or the third prong is provided for your safety. If the provided plug does not fit into your outlet, consult an electrician for replacement of the obsolete outlet.
10. Protect the power cord from being walked on or pinched particularly at the plugs, convenience receptacles, and the point where they exit from the apparatus.
11. Only use attachments/accessories specified by the manufacturer (such as the exclusive supply adapter, battery etc).
12. Use only with a cart, stand, tripod, bracket, or table specified by the manufacturer, or sold with the apparatus. When a cart or rack is used, use caution when moving the cart and apparatus combination to avoid injury from tip-over.



13. Unplug the apparatus during lightning storms or when unused for long periods of time.
14. Refer all servicing to qualified personnel. Servicing is required when the apparatus has been damaged in any way including but not limited to power supply cord or plug damage, liquid ingress, foreign objects in the chassis, exposure to rain/moisture or impact damage. In addition the unit must be serviced when you experience any abnormal operation.
15. CAUTION: These servicing instructions are for use by qualified service personnel only. To reduce the risk of electric shock, do not attempt to perform any servicing other than that contained in the operating instructions unless you are qualified to do so. In addition opening the casing will result in your warranty becoming null and void.
16. Do not install this apparatus in a confined space such as a book case or similar unit. Good ventilation should be maintained around the apparatus and any vents, air-inlets or fans should not be obstructed by objects such as paper, table-cloths, curtains etc.
17. WARNING: To reduce the risk of fire or electric shock, do not expose the apparatus to rain or moisture. The apparatus should not be exposed to dripping or splashing and objects filled with liquids, such as vases, should not be placed on the apparatus.
18. WARNING: The mains plug is used as a disconnect device, the disconnect device shall remain readily operable.



19. This lightning flash with arrowhead symbol within an equilateral triangle is intended to alert the user to the presence of non-insulated “dangerous voltage” within the product’s enclosure that may be of sufficient magnitude to constitute a risk of electric shock.
Warning: To reduce the risk of electric shock, do not remove the cover (or back) as there are no user-serviceable parts inside. Refer servicing to qualified personnel.
The exclamation point within an equilateral triangle is intended to alert the user to the presence of important operating and maintenance instructions in the literature accompanying the appliance.
20.  This equipment is a Class II or double insulated electrical appliance. It has been designed in such a way that it does not require a safety connection to electrical earth.
21.  Correct Disposal of this product. This marking indicates that this product should not be disposed with other household wastes throughout the EU. To prevent possible harm to the environment or human health from uncontrolled waste disposal, recycle it responsibly to promote the sustainable reuse of material resources. To return your used device, please use local return and collection systems or contact the retailer where the product was purchased. They can take this product for safe environmentally friendly recycling.

INTRODUCTION

Congratulations on the purchase of your CONNECT series mixer. CONNECT series mixers are the result of many years of experience in the use, design and manufacture of professional audio equipment. We take great pride in engineering and building every Wharfedale Pro product and wish to thank you for entrusting us with your sound.

From the time Gilbert Briggs built his first loudspeaker in 1932, to the present day, Wharfedale have maintained the same standard of quality in components, workmanship and performance.

Please take the time to read this manual completely in order to ensure that you get the most from your CONNECT mixer.

ABOUT THE CONNECT MIXERS

The CONNECT mixers from Wharfedale Pro are high quality compact mixers that are suitable for a wide range of applications.

Professional big mixer features such as Phantom powered, balanced XLR microphone inputs give you full functionality and great sound in an ultra compact and cost effective package that is ideal for live sound, home studio recording and fixed installations. The Microphone pre-amplifiers use the same high quality components and construction methods that are employed in our flagship mixers.

All CONNECT mixers feature an intuitive, ergonomically designed user interface that is excellent for beginners and professionals alike. Comprehensive connectivity ensures that a CONNECT mixer will fit into any situation you need.

COMMON FEATURES

- **High quality microphone preamplifiers, with switchable global +48V phantom power**
- **Balanced XLR Mic/Mono inputs with input gain control**
- **Stereo Channels with Balanced/Unbalanced 1/4" TRS Inputs**
- **Pan/Balance controls for all channels**
- **Clip LED for all mono channels**
- **Separate Main Mix and Phones outputs with level controls**
- **Stereo 4 segment LED meters**
- **Stereo 1/4" Headphones outputs**
- **Full duplex 16 bit/48 kHz USB interface, with destination switches**

CONNECT 502USB FEATURES

- 1 Mono Mic/Line Channel and 2 Stereo Channels
- 2 Band EQs for mono channel

CONNECT 802USB FEATURES

- 2 Mono Mic/Line Channels and 2 Stereo Channels
- 3 Band EQs for all channels

CONNECT 1002FX/USB FEATURES

- 2 Mono Mic/Line Channels and 8 Stereo Line Channels
- 3 Band EQs and switchable high pass filter for all mono channels
- Built-in 56 effects digital FX with LED display
- Control room, FX Send/AUX and Headphones outputs

CONNECT 1202FX/USB FEATURES

- 4 Mono Mic/Line Channels and 8 Stereo Line Channels
- 3 Band EQs and switchable high pass filter for all mono channels
- Built-in 56 effects digital FX with LED display
- Control room, FX Send/AUX and Headphones outputs

USB INTERFACE

The USB connector enables computers with USB connectivity to interface directly with the CONNECT mixer for full duplex recording and playback. In recent years the introduction of USB connectivity has ushered a new appreciation of the capabilities of computer audio, helping to fuse both digital and analogue and open up endless possibilities for the recording musician.

The internal AD (Analogue to Digital) and DA (Digital to Analogue) converters are 16-bit/48KHz enabling recording and playback above CD quality, ensuring that recordings that you make with a CONNECT mixer have outstanding quality.

The CONNECT mixer is fully class compliant and requires no drivers when used with modern operating systems. Mac OSX, Windows XP, Vista and 7 will require no additional driver software.

Windows WIN7 Installation

Simply choose the device in the following location: Start > Control Panel > Hardware and Sound > Sound > Manage Audio Devices

Mac OSX Installation

Simply select as an input and output device using the "Audio MIDI Setup" page, you can find this easily using the spotlight function.

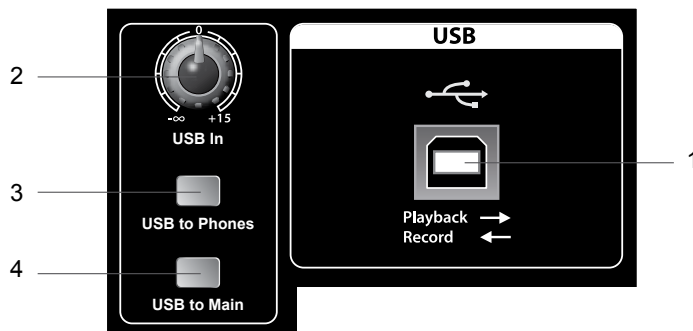

1. USB Connector for Class Compliant Interfacing with a PC or Mac.
2. Controls the level of the USB inputs.
3. Sends the USB input signal to the headphone outputs.
4. Sends the USB input signal to the main mix bus.

FX Interface



You have a choice of 56 different effects, from Reverb to Flanging to Delay. You can send them to the main mix outputs.

- 1. Shows the code of the selected effect
- 2. Shows when the FX bus is overloaded
- 3. Turns the FX processor on or off
- 4. Selects the effect algorithm as listed below the control
- 5. Sends the output of the FX processor to the main mix bus

ROOM	r1 Closet, r2 Small ambient room, r3 Small bathroom, r4 Medium bathroom, r5 Large bathroom, r6 Small empty room, r7 Medium empty room, r8 Large empty room.
PLATE	P1 - P5
HALL	h1 Medium hall 1, h2 Medium hall 2, h3 Medium hall 3, h4 Large hall 1, h5 Large hall 2, h6 Large hall 3, h7 Church, h8 Cathedral.
GATED REVERB	g1 - g3
CHORUS	c1 - c4 Chorus 1-4, c5 - c8 Chorus with reverb 1-4.
FLANGER	F1 - F6 Flanger 1-6, F7 - F9 Flanger with reverb 1-2.
ROTARY SPEAKER	S1 - S7
DELAY	d1 - d9

WALKTHROUGH—CONNECT 502USB

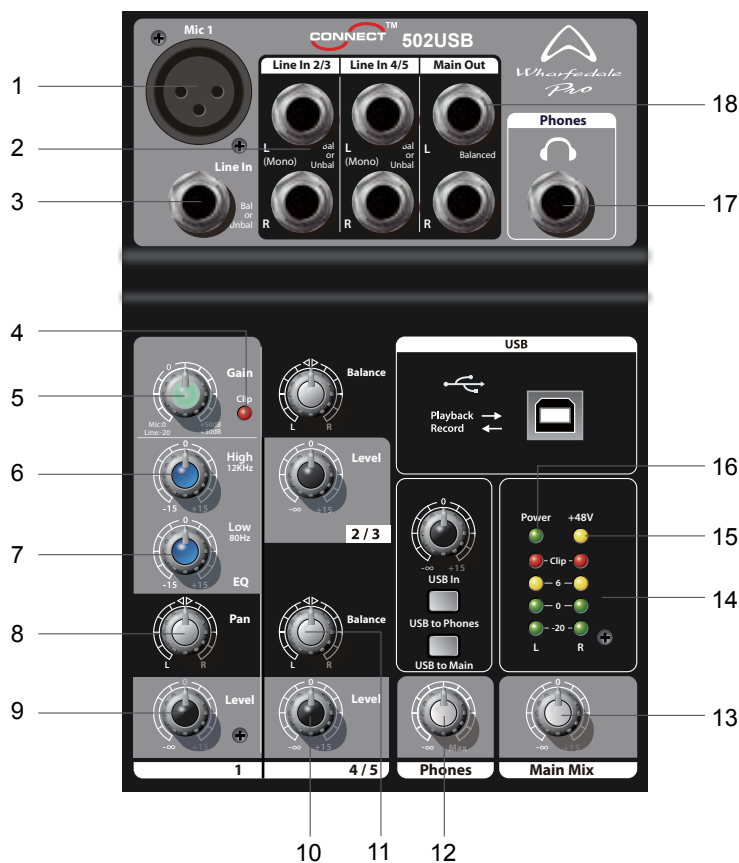

1. Balanced XLR input for microphone
2. Balanced/Unbalanced TRS input for line level sources (for the STEREO channel)
3. Balanced/Unbalanced TRS input for line level sources
4. Clip LED lit when the signal is overloaded
5. Gain control for calibrating sources and applying correct gain structure
6. High EQ centred at 12KHz
7. Low EQ centred at 80Hz
- 8/11. Pan/Balance used to spatially place the channel within the stereo field
- 9/10. Set the amount of signal to the main mix bus
12. Set the amount of signal to the headphones output
13. Control the master level of the main outputs.
14. Display the realtime level present at the main output bus
15. Indicates +48v phantom power activity
16. Indicates AC power supply
17. To connect headphones
18. Balanced/unbalanced TRS main outputs

WALKTHROUGH—CONNECT 802USB



1. Balanced XLR input for microphone
2. Balanced/Unbalanced TRS input for line level sources (for the STEREO channel)
3. Balanced/Unbalanced TRS input for line level sources
4. Clip LED lit when the signal is overloaded
5. Gain control for calibrating sources and applying correct gain structure
6. High EQ centred at 12kHz
7. Mid EQ centred at 1kHz
8. Low EQ centred at 80Hz
9. Pan/Balance used to spatially place the channel within the stereo field
10. Set the amount of signal to the main mix bus
11. Set the amount of signal to the headphones output
12. Controls the master level of the main outputs
13. Displays the realtime level present at the main output bus
14. To connect headphones
15. Balanced/unbalanced TRS main outputs

WALKTHROUGH—CONNECT 1002FX/USB (also for 1202)

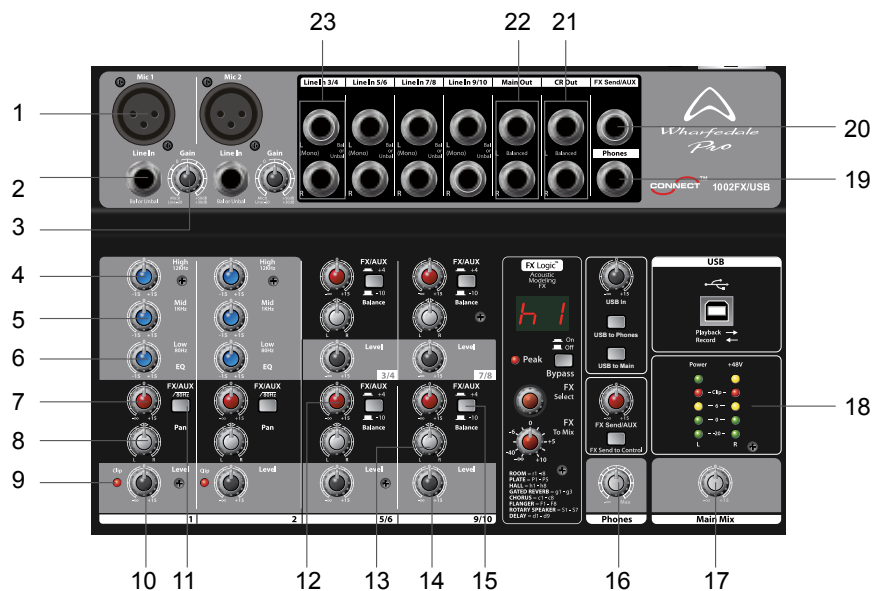

1. Balanced XLR input for microphone
2. Balanced/Unbalanced TRS input for line level sources
3. Gain control for calibrating sources and applying correct gain structure
4. High EQ centred at 12kHz
5. Mid EQ centred at 1kHz
6. Low EQ centred at 80Hz
- 7/12. Set the amount of signal to the internal FX processor and AUX output path
- 8/13. Pan/Balance used to spatially place the channel within the stereo field
9. Clip LED lit when the signal is overloaded
- 10/14. Sets the amount of signal sent to the main mix bus
11. Activate the high pass filter with 80Hz cut-off point
15. Select the sensitivity for the different level sources.
16. Set the amount of signal to the headphones output
17. Controls the master level of the main outputs
18. Display the realtime level present at the main output bus
19. To connect headphones
20. Send the signal out to the external effector or the external AUX instrument
21. Send the signal out for the control room monitoring
22. Balanced/unbalanced TRS main outputs
23. Balanced/Unbalanced TRS input for line level sources (for the STEREO channel)

WALKTHROUGH—REAR PANEL



1. Turn the Connect Mixer on or off
2. AC power supply receptacle

CAUTION:

USE THE POWER ADAPTER AUTHORISED BY Wharfedale Pro ONLY!

3. Switch the global +48V phantom power on or off

WIRING DIAGRAM

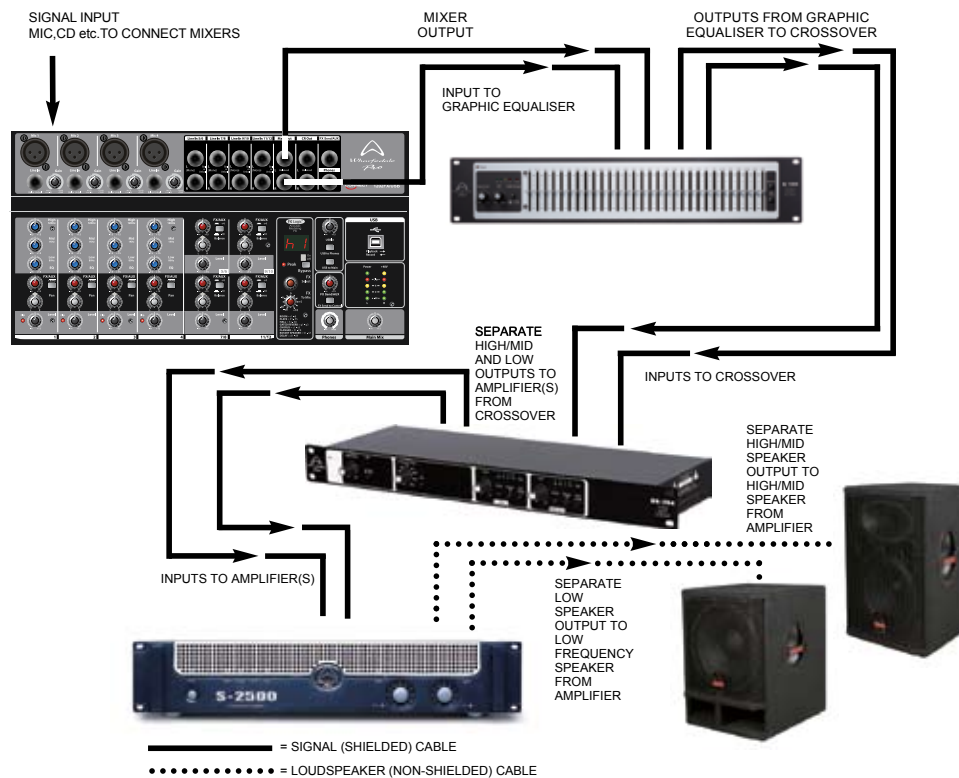

DIMENSIONAL DRAWING

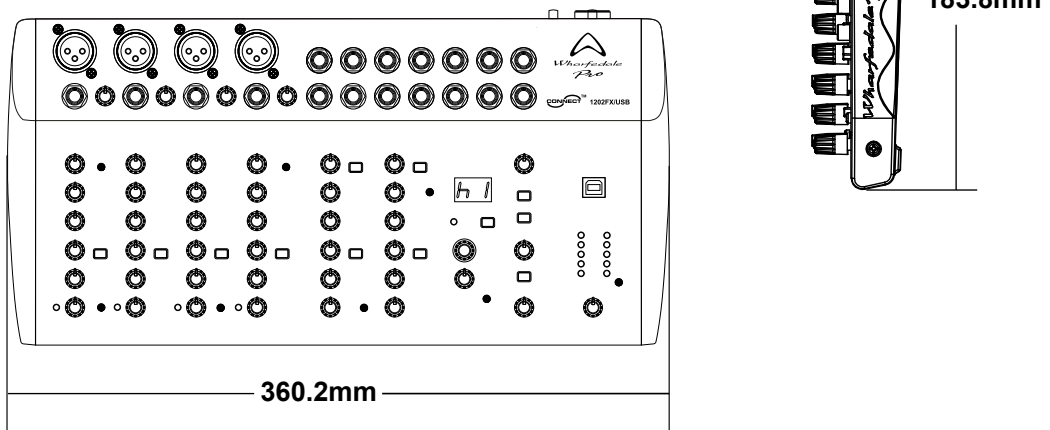
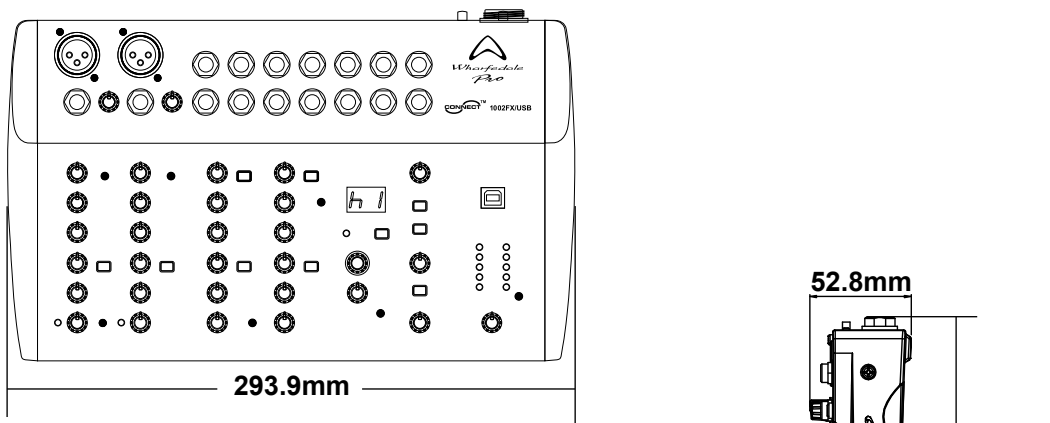
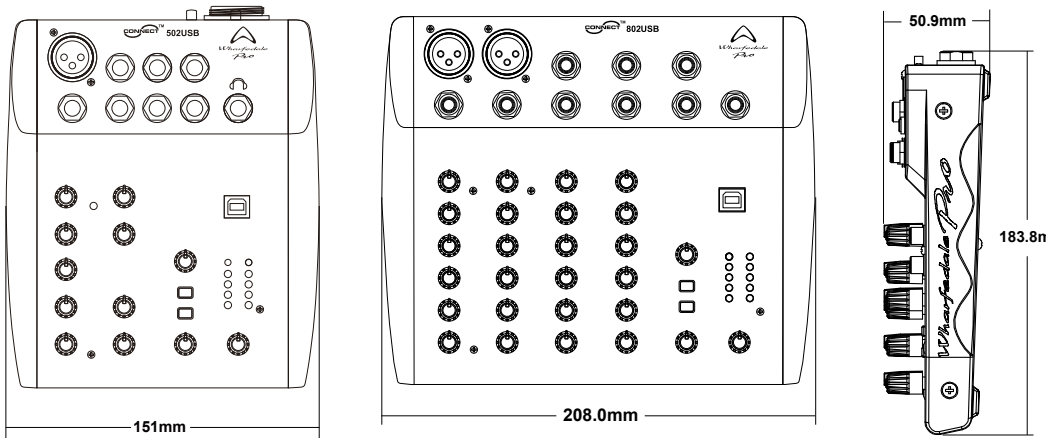

BLOCK DIAGRAM—CONNECT 502USB

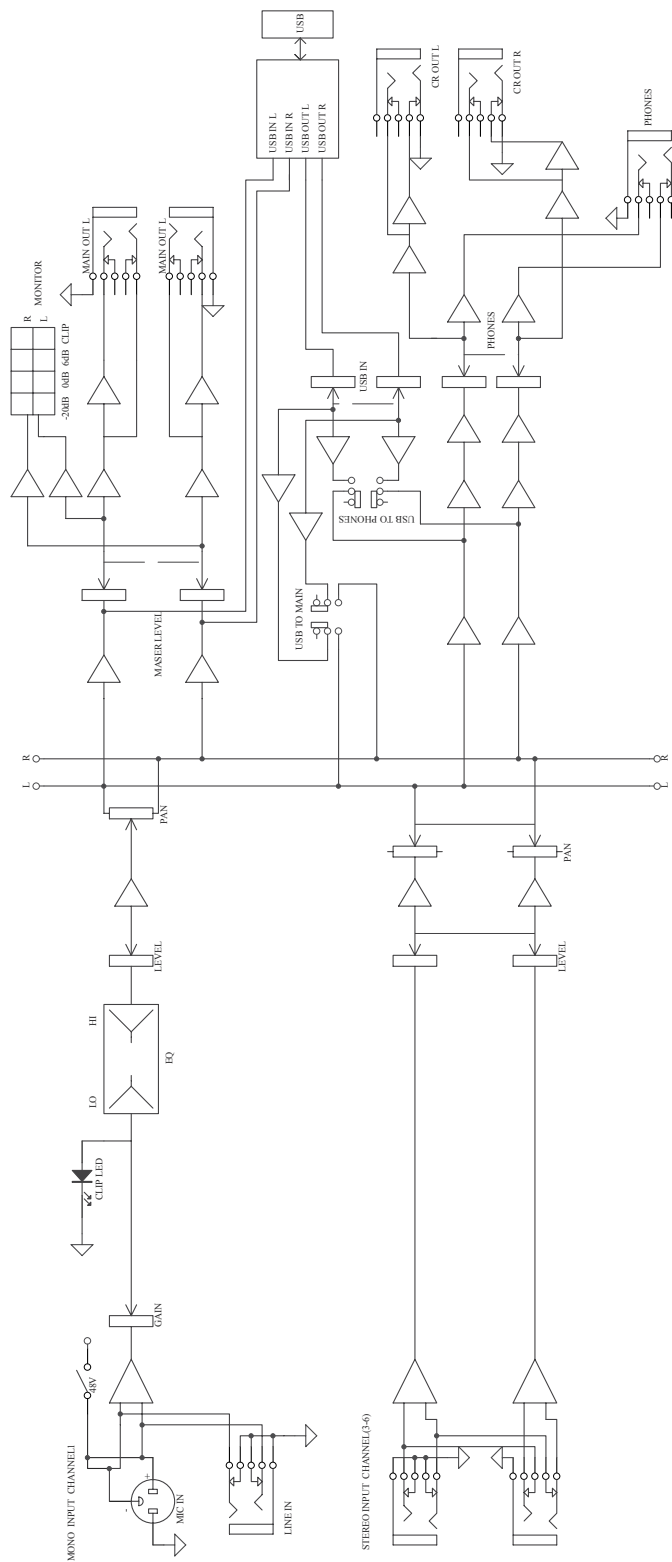

BLOCK DIAGRAM—CONNECT 802USB

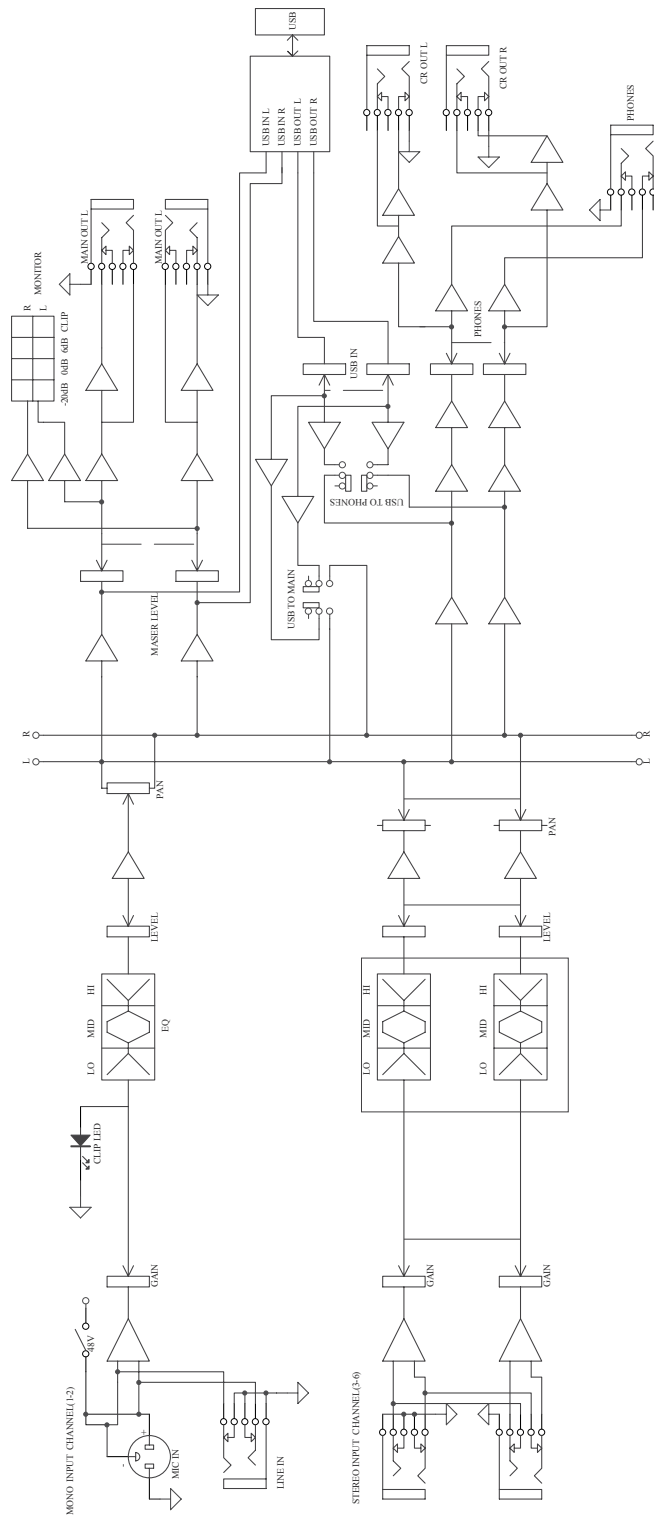

BLOCK DIAGRAM—CONNECT 1002FX/USB

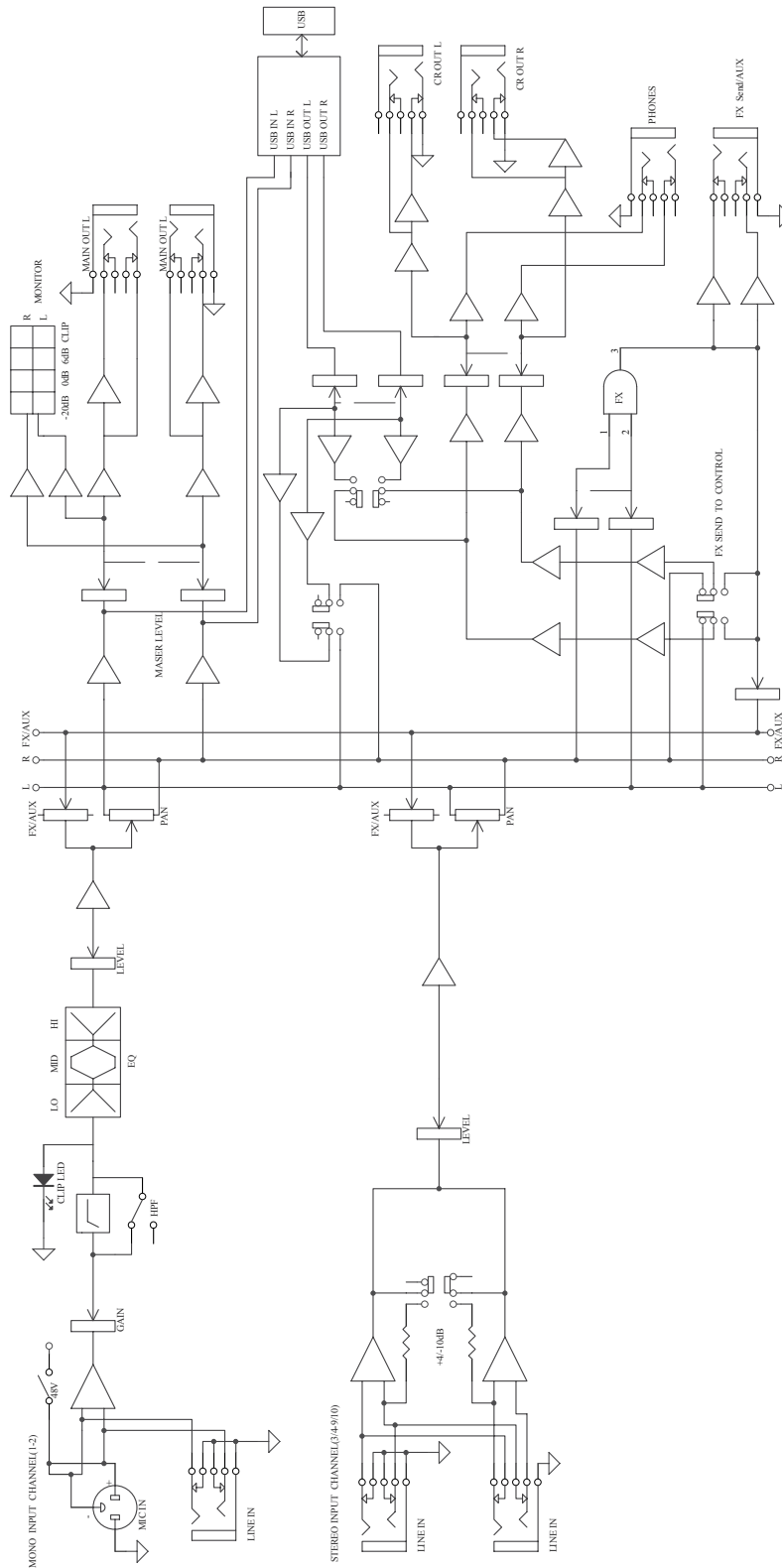

BLOCK DIAGRAM—CONNECT 1202FX/USB

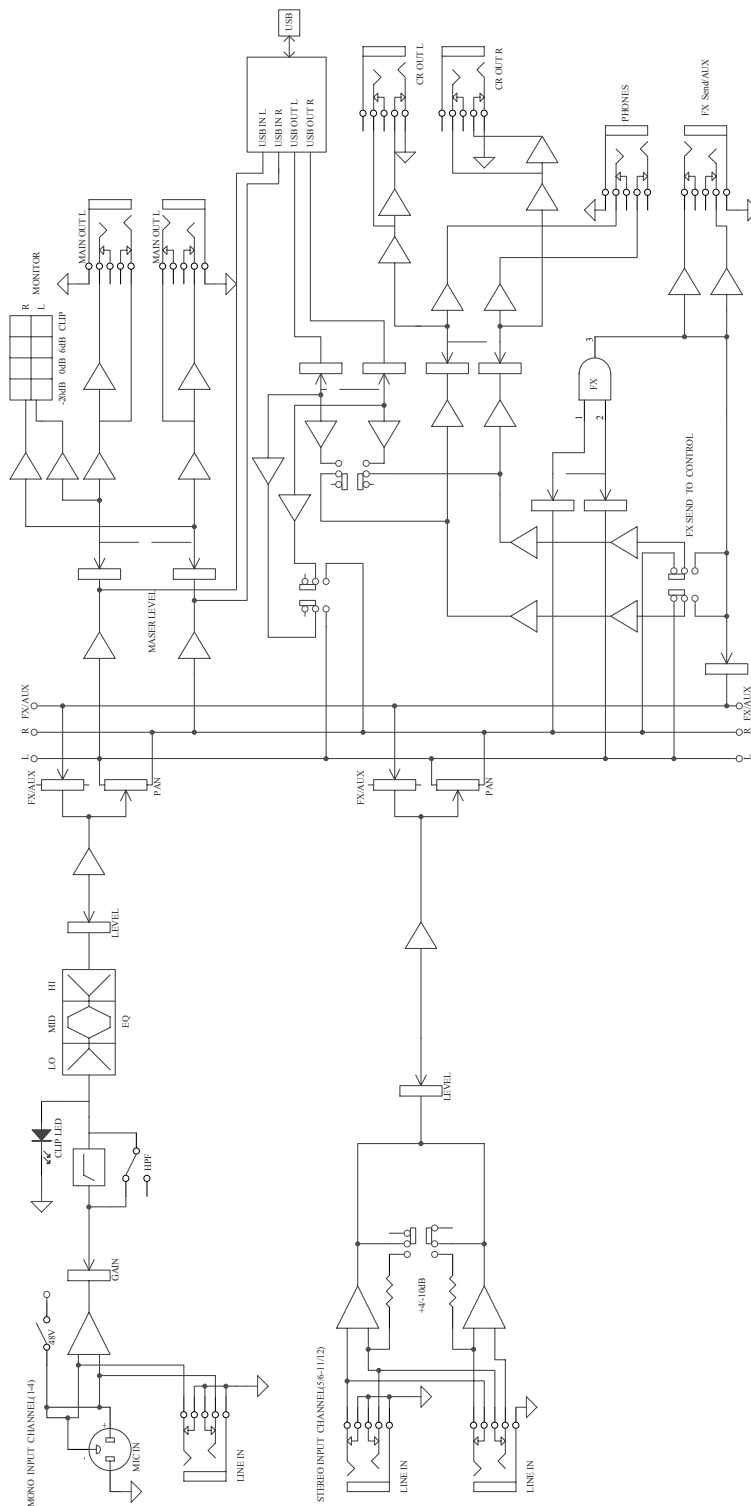

SPECIFICATIONS-502USB/802USB

Model	CONNECT 502USB	CONNECT 802USB
Maximum Balanced Output Level (1%T.H.D. at 1kHz)	Main 1/4" Jack Balanced out +21dBu +/-1dBu Headphones output 150mw +/-5mw @ 32ohms	Main 1/4" Jack Balanced out +21dBu +/-1dBu Headphones output 150mw +/-5mw @ 32ohms
THD+N	<0.025% @ + 14dBu +/-0.5dBu	<0.025% @ + 14dBu +/-0.5dBu
Frequency Response	20Hz~20kHz +/-2dB	20Hz~20kHz +/-2dB
Hum and Noise 20Hz-20Khz(150R)	-127dBu +/-5dBu Mic Pre Equivalent Input Noise -85dBu +/-5dBu Residual Noise	-127dBu +/-5dBu Mic Pre Equivalent Input Noise -85dBu +/-5dBu Residual Noise
S/N	>78dB+5dB @ pot max	>78dB+5dB @ pot max
FFT	< -62dBv+/-5dBv @ gain pot max	< -62dBv+/-5dBv @ gain pot max
CMRR	62dB+/-5dB @ 1kHz	62dB+/-5dB @ 1kHz
Maximum Input Level	Mic: +4dBu +/-1dBu Stereo Line: +21dBu +/-1dBu	Mic: +4dBu +/-1dBu Stereo Line: +21dBu +/-1dBu
Impedances	Mic: Balanced 6Kohms, Unbalanced 3Kohms +/-200ohms Line: Balanced 22Kohms, Unbalanced 11 Kohms +/-2kohms All other Unbalanced outputs:60 ohms,Balanced outputs: 120ohms	Mic: Balanced 6Kohms, Unbalanced 3Kohms +/-200ohms Line: Balanced 22Kohms, Unbalanced 11 Kohms +/-2kohms All other Unbalanced outputs:60 ohms,Balanced outputs: 120ohms
Mono Input Channel Gain	50dB Variable MIC(0~50dB) Line(-20dB~+30dB)	50dB Variable MIC(0~50dB) Line(-20dB~+30dB)
Input Channel EQ	High (+/-15dB)+/-1.5dB 12kHz Shelving Low (+/-15dB)+/-1.5dB 80Hz Shelving	High (+/-15dB)+/-1.5dB 12kHz Shelving Mid (+/-15dB)+/-1.5dB 1kHz Shelving Low (+/-15dB)+/-1.5dB 80Hz Shelving
Level Meter	4-Segment LEDx2 (output of +4dB = 0) Main L/R	4-Segment LEDx2 (output of +4dB = 0) Main L/R
AC POWER	120V, 60Hz; 220V, 50Hz; 230V, 50Hz; 240V, 50Hz	120V, 60Hz; 220V, 50Hz; 230V, 50Hz; 240V, 50Hz
Dimensions (H x W x D)	50.9*151*183.8 mm (2.0*5.9*7.2 in.)	50.9*208*183.8 mm (2.0*8.2*7.2 in.)
Weight (Net/Gross)	0.64kg /1.62kg	0.92kg /1.9kg

SPECIFICATIONS-1002USB/1202USB

Model	CONNECT 1002FX/USB	CONNECT 1202FX/USB
Maximum Output Level (1%THD at 1kHz)	Main 1/4" Jack Balanced out +26dBu ± 1dBu, Unbalanced out +21dBu ±1dBu Headphones output 150mw±5mw @ 32ohms	Main 1/4" Jack Balanced out +26dBu ± 1dBu, Unbalanced out +21dBu ±1dBu Headphones output 150mw±5mw @ 32ohms
THD+N	<0.019% @ + 14dBu ±0.5dBu	<0.025% @ + 14dBu ±0.5dBu
Frequency Response	20Hz~20kHz±1dB	20Hz~20kHz±1dB
Hum and Noise 20Hz-20Khz(150R)	-127dBu ±5dBu Mic Pre Equivalent Input Noise -85dBu ±5dBu Residual Noise	-127dBu ±5dBu Mic Pre Equivalent Input Noise -85dBu ±5dBu Residual Noise
S/N	82dB ±5dB @ fader max	78dB ±5dB @ fader max
FFT	-62dBv ±5dBv @ gain fader max	-62dBv ±5dBv @ gain fader max
CMRR	60dB±5dB @ 1kHz	62dB±5dB @ 1kHz
Maximum Input Level	Mic: +4dBu ±1dBu Channel Line: +25dBu±1dBu Stereo Line: +25dBu ±1dBu	Mic: +4dBu ±1dBu Channel Line: +25dBu±1dBu Stereo Line: +25dBu ±1dBu
Impedances	Mic: Balanced 6 Kohms, Unbalanced 3Kohms ±500ohms Line: Balanced 44 Kohms, Unbalanced 22Kohms ±2kohms All other Unbalanced outputs:100 ohms,Balanced outputs: 200ohms	Mic: Balanced 6 Kohms, Unbalanced 3Kohms ±500ohms Line: Balanced 44 Kohms, Unbalanced 22Kohms ±2kohms All other Unbalanced outputs:100 ohms,Balanced outputs: 200ohms
Mono Input Channel Gain	50dB Variable MIC(0~50dB) Line(-20dB~+30dB)	50dB Variable MIC(0~50dB) Line(-20dB~+30dB)
Input Channel EQ	High (+/-15dB)±2dB 12kHz Shelving Mid (+/-15dB)±2dB 1kHz Shelving Low (+/-15dB)±2dB 80Hz Shelving	High (+/-15dB)±2dB 12kHz Shelving Mid (+/-15dB)±2dB 1kHz Shelving Low (+/-15dB)±2dB 80Hz Shelving
Effect Out	56 effects: 1.(ROOM=r1-r8); 2.(PLATE=P1-P5); 3.(HALL=h1-h8); 4.(GATED REVERB=g1-g3); 5.(CHORUS=c1-c8) 6.(FLANGRE=f1-f8); 7.(ROTARY SPEAKER=s1-s7); 8.(DELAY=d1-d9).	56 effects: 1.(ROOM=r1-r8); 2.(PLATE=P1-P5); 3.(HALL=h1-h8); 4.(GATED REVERB=g1-g3); 5.(CHORUS=c1-c8) 6.(FLANGRE=f1-f8); 7.(ROTARY SPEAKER=s1-s7); 8.(DELAY=d1-d9).
Level Meter	4-Segment LEDx2 (output of +4dBu = 0) Main L/R	4-Segment LEDx2 (output of +4dBu = 0) Main L/R
AC Power	120V, 60Hz; 220V, 50Hz; 230V, 50Hz; 240V, 50Hz	120V, 60Hz; 220V, 50Hz; 230V, 50Hz; 240V, 50Hz
Dimensions(HxWxD)	52.8*293.9*183.8mm (2.1*11.6*7.3 in.)	52.8*360.2*183.8mm (2.1*14.2*7.3 in.)
Weights(Net/Gross)	1.37kg/3.0kg	1.69kg/3.3kg

WHARFEDALE PRO LIMITED WARRANTY

Wharfedale Pro Connect Series products are warranted of manufacturing or material defects for a period of one year from the original date of purchase. In the event of malfunction, contact your authorized Wharfedale Pro dealer or distributor for information.

*Be aware that warranty details may differ from country to country. Contact your dealers or distributor for information. These terms do not infringe your statutory rights.



Wharfedale Professional

IAG House, 13/14 Glebe Road, Huntingdon, Cambridgeshire, PE29 7DL, UK

www.wharfedalepro.com

Wharfedale Professional reserves the right to alter or improve specifications without notice.
All rights reserved © 2014 Wharfedale Pro. Wharfedale Pro is a member of the IAG Group.