

Delta X Series

OPERATING MANUAL AND USER GUIDE

Delta X10 Delta X12 Delta X15 Delta X12M Delta X15M
Delta X215 Delta X15B Delta X18B Delta X218B



www.wharfedalepro.com

IMPORTANT WARNINGS & SAFETY INSTRUCTIONS

1. READ ALL INSTRUCTIONS – carefully and become familiar with the features and functions of these products before operating them.
2. RETAIN THESE INSTRUCTIONS – for future reference.
3. COMPLY WITH ALL WARNINGS – All warnings and instructions for this product should be adhered to.
4. USE WITH AMPLIFIERS – In order to avoid damage to drivers and other equipment, it is advisable to establish and follow a routine for powering up and powering down a sound system. With all system components connected, turn on source equipment (mixers, signal processors, record and playback units, etc.) BEFORE powering up amplifiers. Transient voltages from powering up source equipment can damage speakers if amplifiers are already turned on. Make sure that amplifier volumes are set to their minimum settings and power up any system amplifiers LAST. It is recommended that all system components be allowed to stabilize for several seconds before any source signals are introduced or level setting adjustments are made. Similarly, when shutting systems down, turn all amplifiers off first, before powering down any other system components.
5. CABLES – Do not use shielded or microphone cables for connection between amplifiers and speakers. Use only approved speaker cables with proper connectors.
6. CAUTION – These professional loudspeaker systems are capable of generating very high sound pressure levels. Use care with placement and operation to avoid exposure to excessive volume levels. Permanent hearing damage can result when operated to extreme levels.
7. SERVICE – There are no user serviceable parts inside this product. Users should not attempt to service this product. Warranty nullification could result if this is attempted.
8. RIGGING - SUSPENDING - MOUNTING - Rigging suspending or mounting of speaker systems can expose members of the public to serious health risks and even death.

UNDER NO CIRCUMSTANCES ATTEMPT TO RIG, SUSPEND OR OTHERWISE MOUNT THESE SPEAKERS UNLESS YOU ARE FULLY QUALIFIED AND CERTIFIED TO DO SO BY RELEVANT LOCAL, STATE AND NATIONAL AUTHORITIES. ALL RELEVANT SAFETY REGULATIONS MUST BE FOLLOWED. IF YOU ARE NOT PROPERLY QUALIFIED OR DO NOT KNOW OF PERTINENT REGULATIONS, CONSULT QUALIFIED PERSONNEL FOR ADVICE.

TABLE OF CONTENTS

Important Warnings & Safety Instructions..... 1

Introduction..... 3

Models/Features 4

Installation..... 5

Delta X10/X12/X12M/X15/X15M/X215 Bi-Amp Wiring 6

Delta X10/X12/X12M/15/X15M/X215 Full range Wiring 7

Delta X15B/X18B Full range Wiring 8

Delta X15B/X18B Bi-Amp Wiring..... 9

Delta X Series Suggested Network Settings..... 10

Rigging/Suspending 11

Block/Wiring Diagrams 12

Dimensional Drawings 19

Specifications 23

Warranty 26

INTRODUCTION

Delta X builds on the global success of the Wharfedale Pro Delta series.

Constructed from 15 mm plywood and covered in the highest quality Rhino Rock paint, the Delta X models are instantly recognizable by their engraved iconic Wharfedale Pro 'boomerang' logo on their cabinets. The fresh cosmetic design however is not the only improvement the engineering team have made.

Internally Delta X also has a new crossover design and construction. Using new component positioning and bracing, the sensitive crossover electronics have been re-engineered to improve long term performance and reliability - even at the highest of volumes.

With rear panel switching, Delta X can operate in either Bi-Amp or Full range modes. This routing flexibility allows for Delta X systems to be refined using multiple amplifiers and external crossovers.

Custom Wharfedale Pro transducers have also been selected. High output, low physical distortion cast frame woofers deliver unparalleled low frequency response. With the exception of the Delta X10, 2" titanium compression drivers are coupled to 90°x45°elliptical waveguides for impressive output level and smooth HF dispersion.

With a full lineup of 9 models, ranging from the 300 w RMS Delta X10 to the 1600 w RMS Dual Chamber 2 x 18" Delta X218 subwoofer, Delta X models are perfect for fixed installation and touring applications.

MODELS

- ◆ Delta X10 - Passive Loudspeaker
- ◆ Delta X12 - Passive Loudspeaker
- ◆ Delta X12M - Passive Stage Monitor
- ◆ Delta X15 - Passive Loudspeaker
- ◆ Delta X15M - Passive Stage Monitor
- ◆ Delta X215 - Passive Loudspeaker
- ◆ Delta X15B - Passive Subwoofer
- ◆ Delta X18B - Passive Subwoofer
- ◆ Delta X218B - Passive Dual Chamber Subwoofer

FEATURES

- ◆ High power, low distortion cast frame woofers
- ◆ 1" exit, 1.75" titanium diaphragm compression drivers(only Delta X10)
- ◆ 1.4" exit, 2" titanium diaphragm compression drivers
- ◆ Externally switchable full range/bi-amp operation
- ◆ Externally switchable discrete/parallel operation (only Delta X218B)
- ◆ 90°x60° elliptical waveguides (only Delta X10)
- ◆ 90°x45° elliptical waveguides
- ◆ Dual angle pole mount receptacles
- ◆ Plywood construction with internal bracing
- ◆ 4-way high impact plastic carry handles
- ◆ Rhino Rock™ texturised composite finish
- ◆ Parallel SpeakON compatible inputs
- ◆ Through outputs on "M" models
- ◆ High-pass outputs on X15B and X18B

INSTALLATION

- Before attempting to install a Delta X Series loudspeaker system please refer to the important warnings and safety instructions. Only qualified personnel should install a loudspeaker system.

Improper installation of a loudspeaker system can cause serious harm and even death if correct procedure is not followed. Anyone attempting installation assumes all liability arising from such use.

- Bi-amp switching - ensure that the internal passive network selector is in the correct position. When using an external active network select the bi-amp setting. Failure to do this can result in damage to the drivers of your Delta X Series loudspeakers.
- Models with dual angle pole mount sockets (Delta X10, Delta X12 and Delta X15) have an angled socket that angles the cabinet down by 10°. This allows more sound to be aimed directly at the audience and less at the ceiling, reducing early reflections. Please ensure that the correct socket is used for each speaker.

DELTA X10/X12/X12M/X15/X15M/X215 BI-AMP WIRING

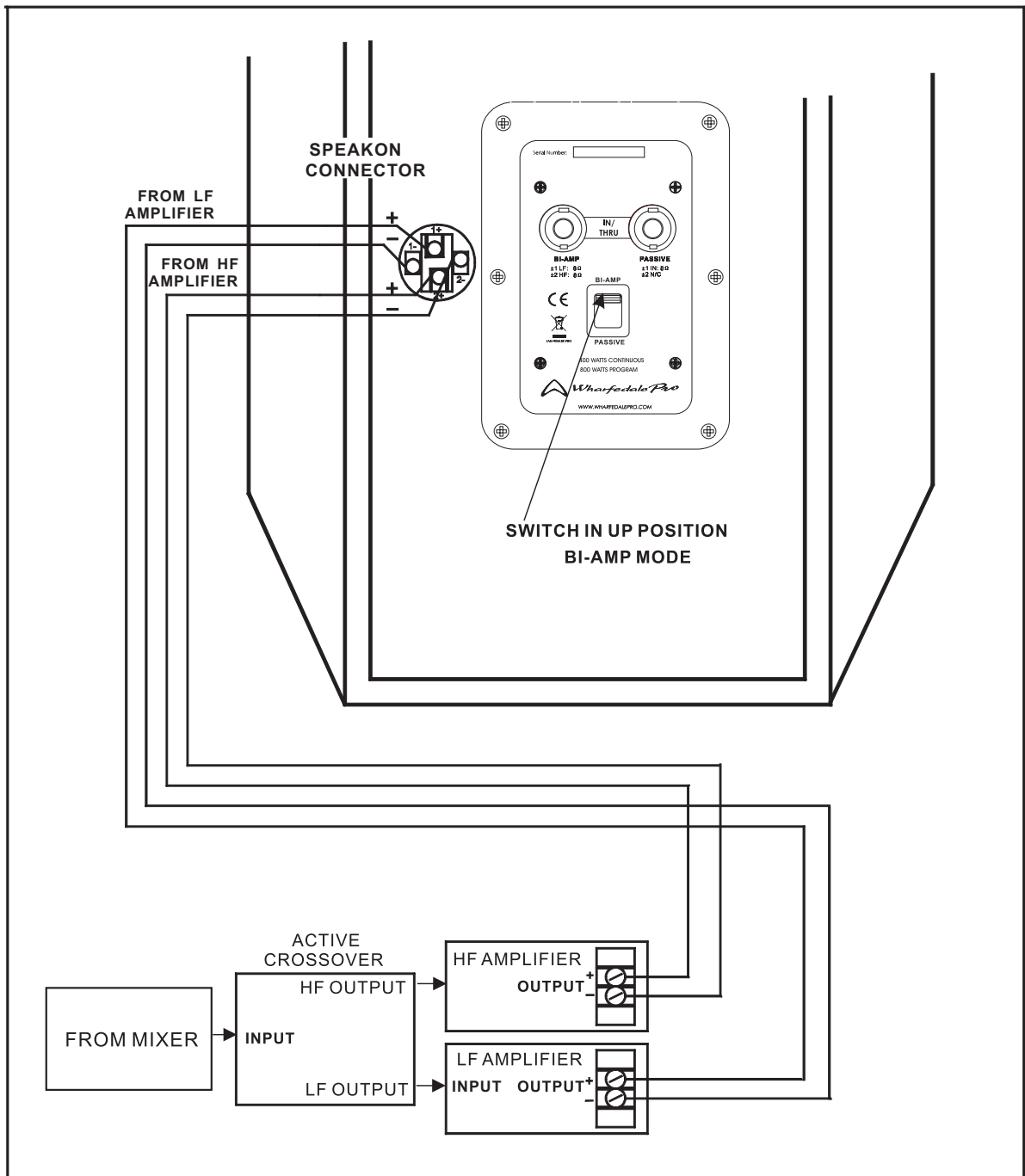

DELTA X10/X12/X12M/X15/X15M/X215 FULLRANGE WIRING

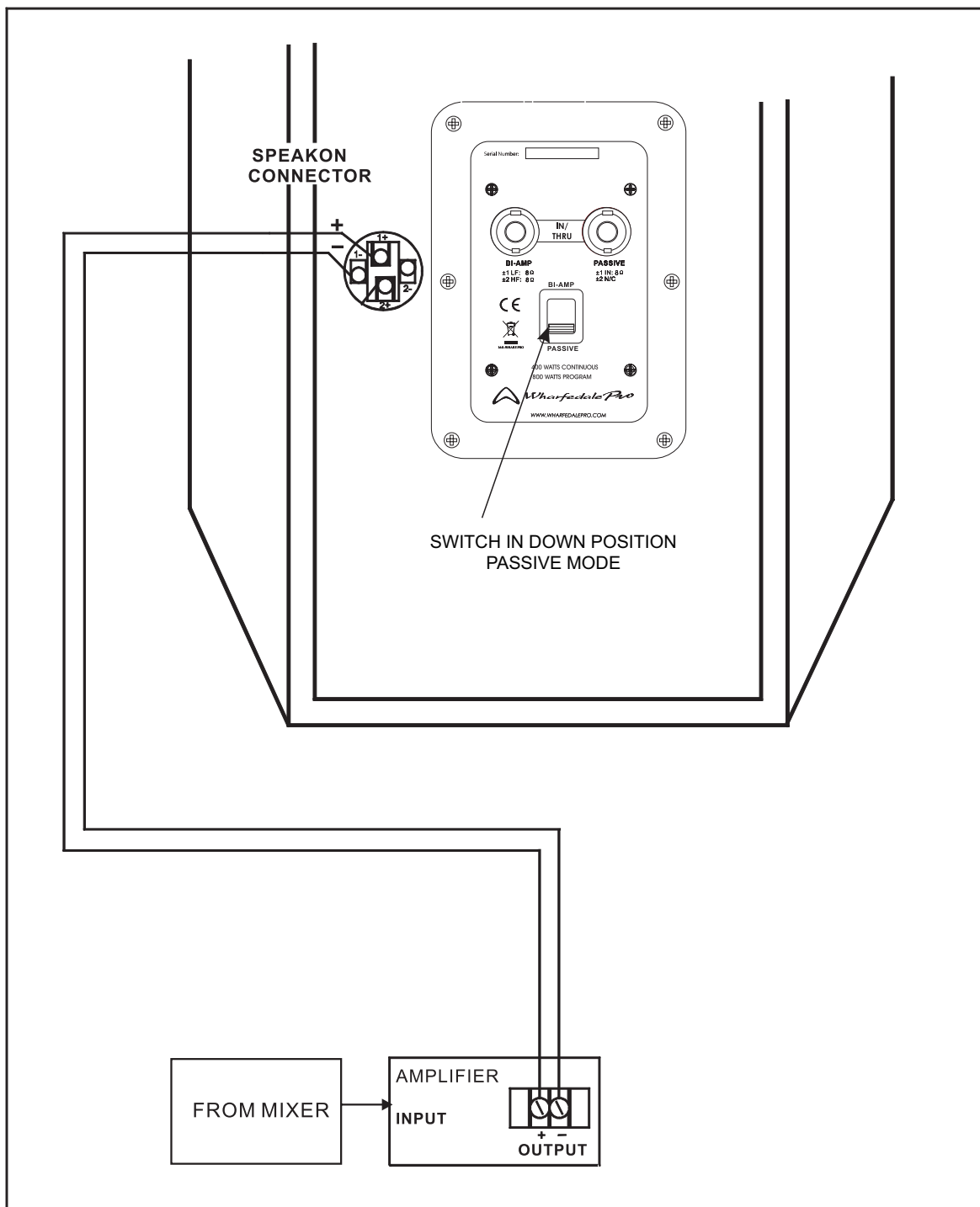

DELTA X15B/X18B FULLRANGE WIRING

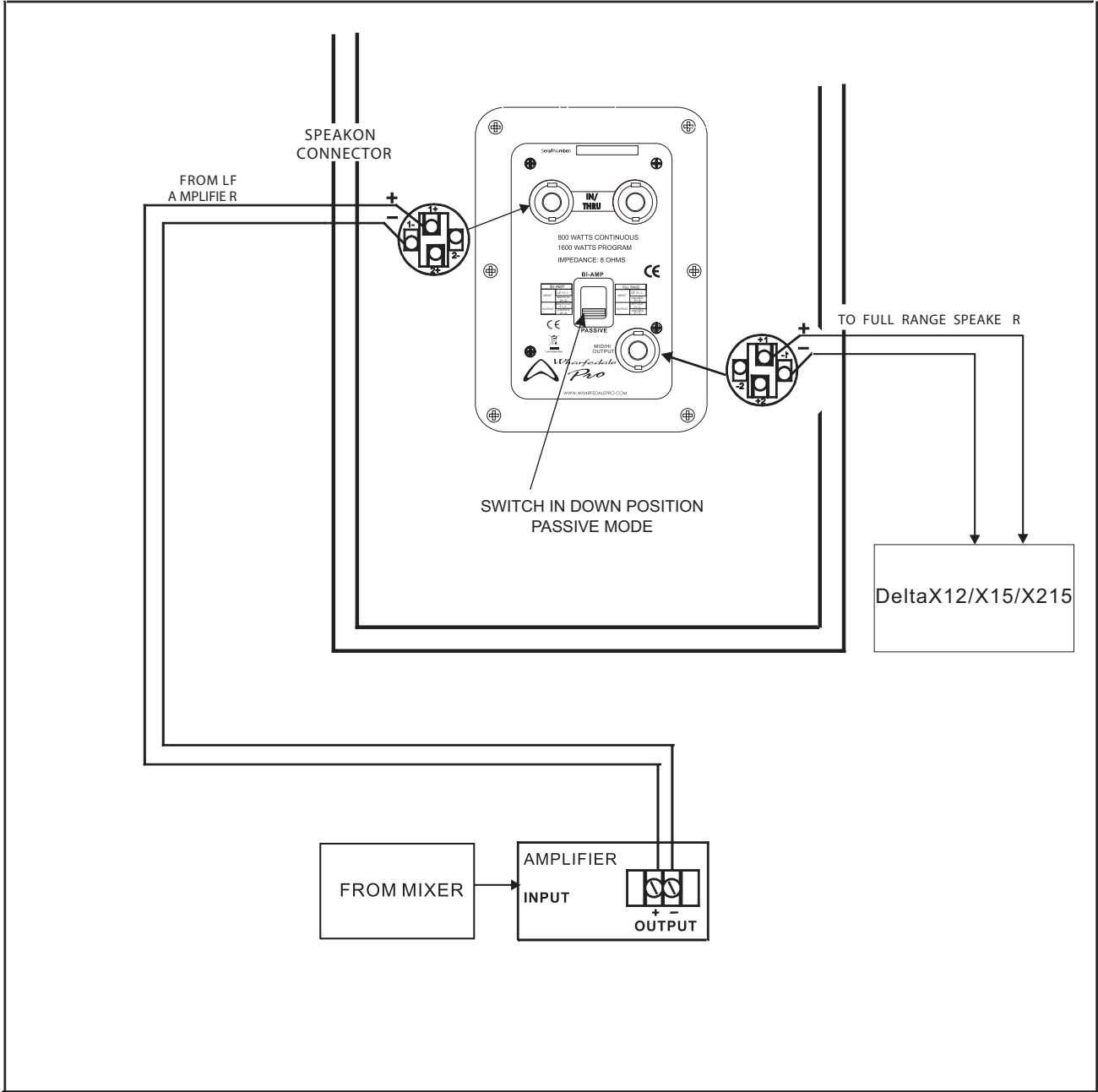

DELTA X15B/X18B BI-AMP WIRING

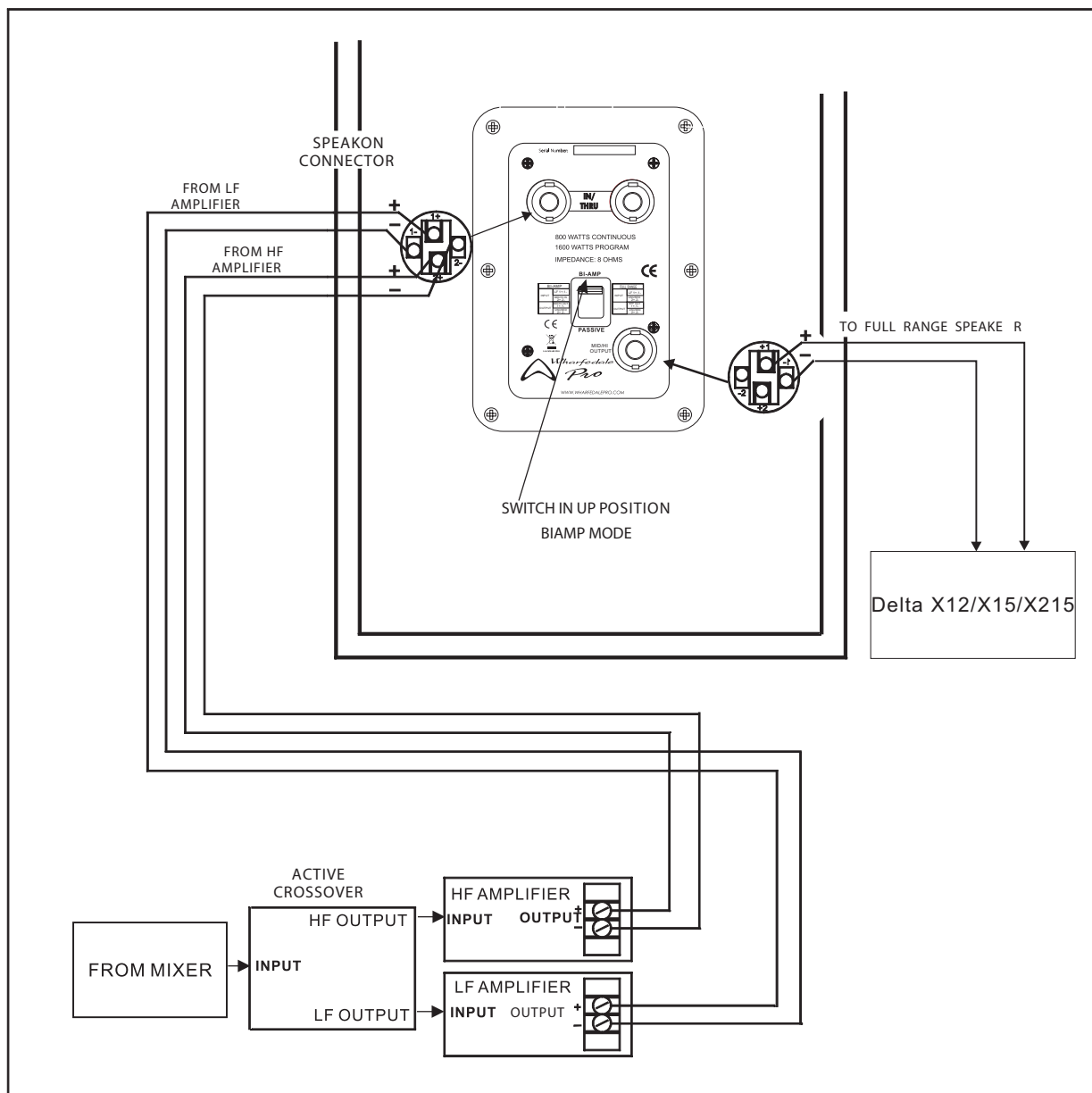

DELTA X SERIES SUGGESTED NETWORK SETTINGS

Delta X10

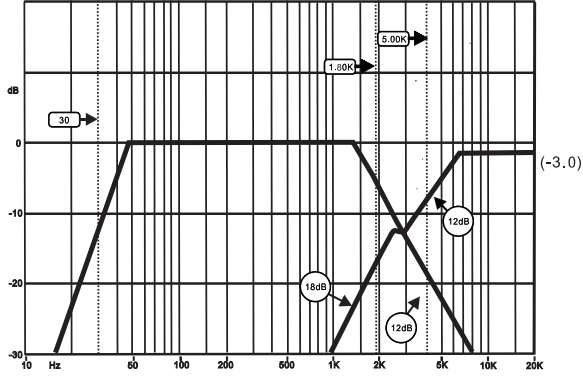

Delta X15

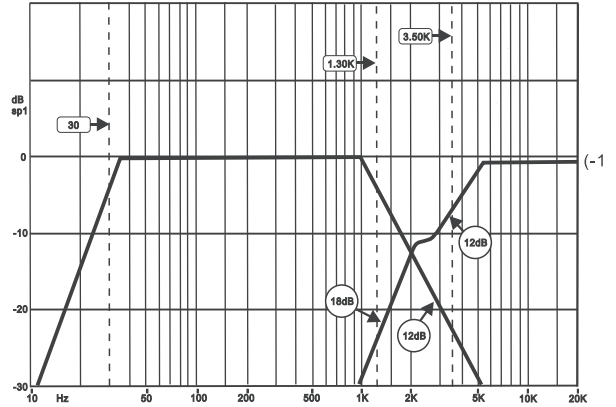

Delta X12

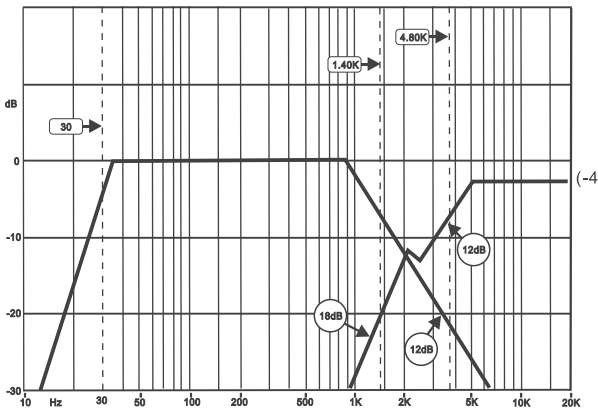

Delta X15M

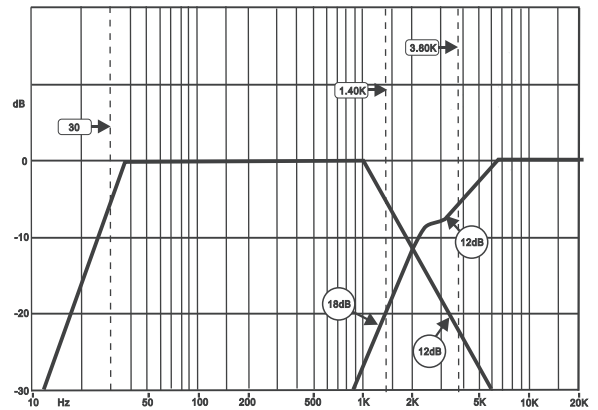

Delta X12M

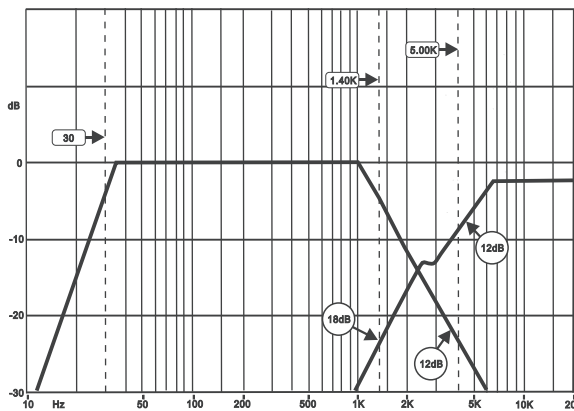

Delta X215

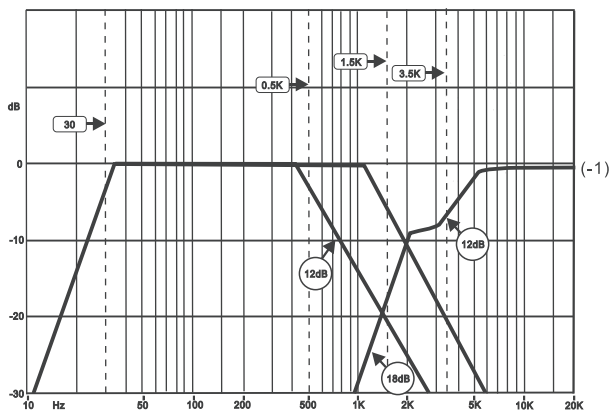

Delta X15B

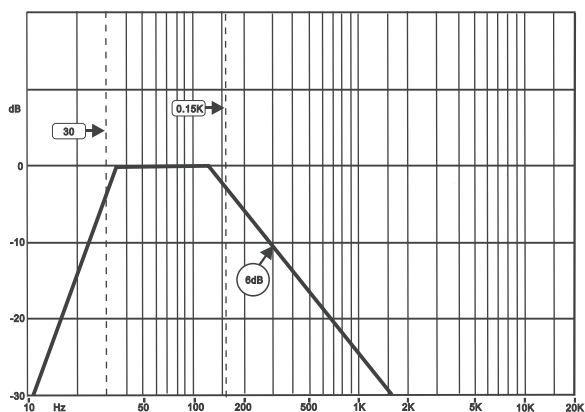

Delta X18B

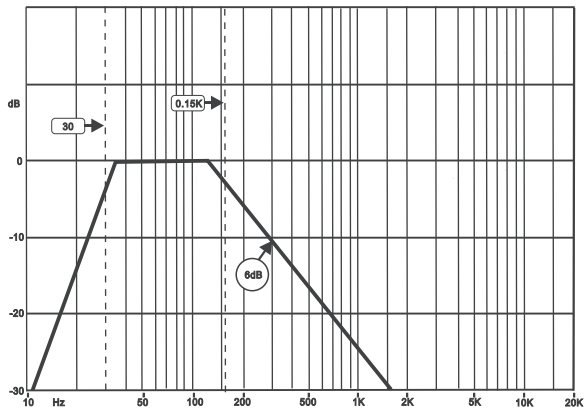

Delta X218B

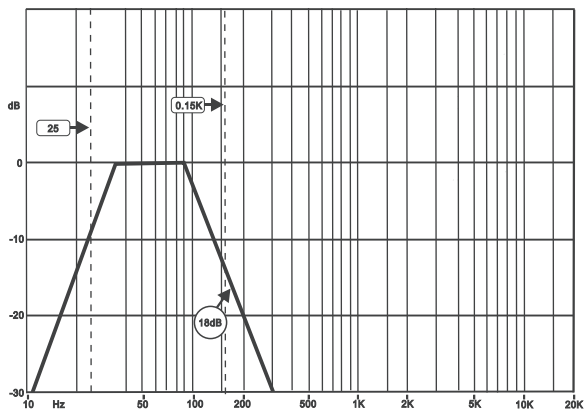

RIGGING/SUSPENDING

Using Shoulder Eyebolts

Always apply the load to the bolt along the plane of the eye. For long term installation use a thread-locking compound. Do not attempt to bend or otherwise deform any rigging hardware.

Please refer to the important safety warnings before you consider suspending any loudspeakers.

Each primary load bearing suspension point shall be rated for the total load.
(A minimum 5:1 Design Factor or Local Standard should be observed, whichever is greater)

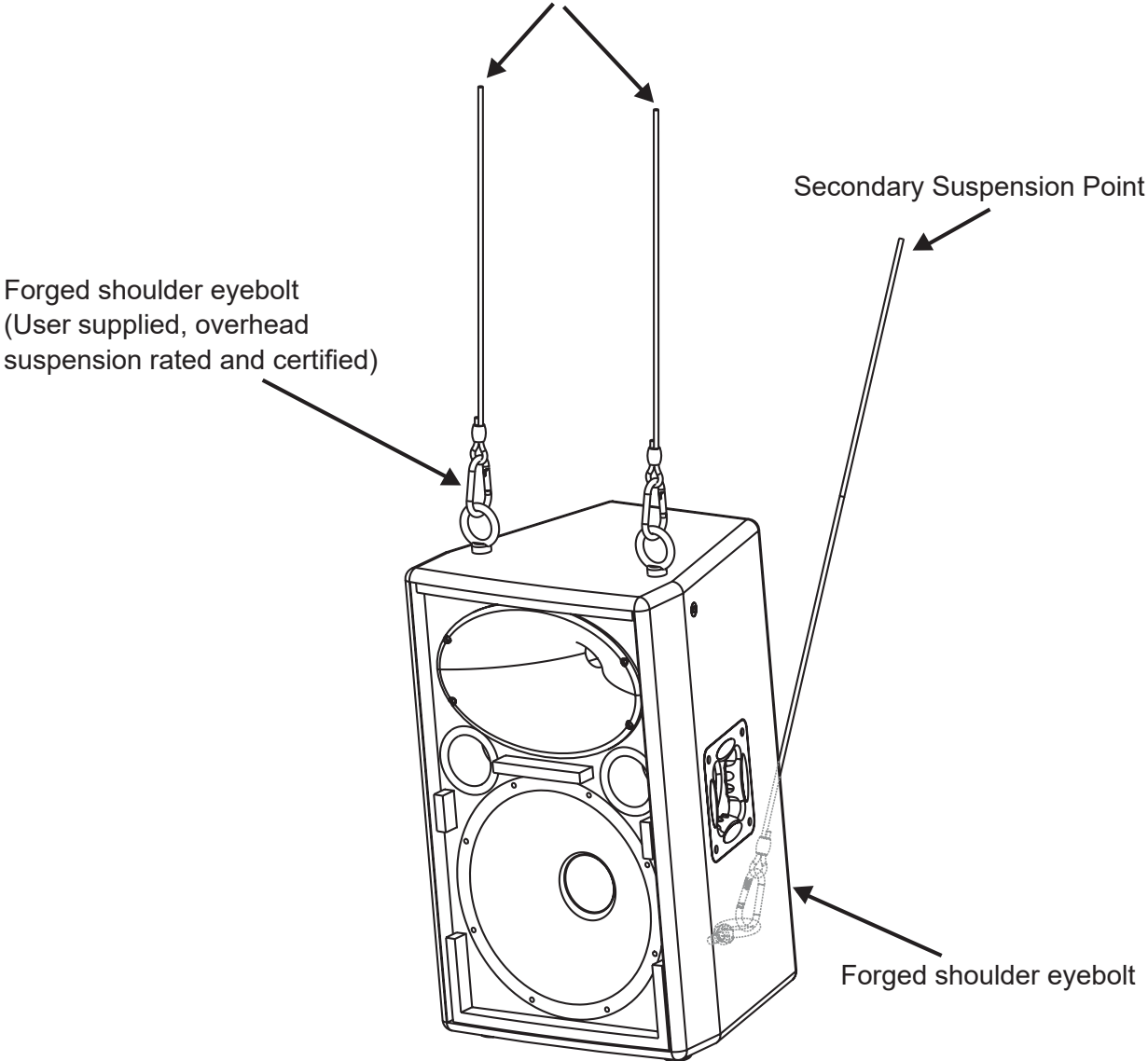

Working load limits: No more than four (4) high (vertical)
The four (4) high vertical specification represents a static ratio of 7:1

BLOCK/WIRING DIAGRAMS

DELTA X10

Block Diagram

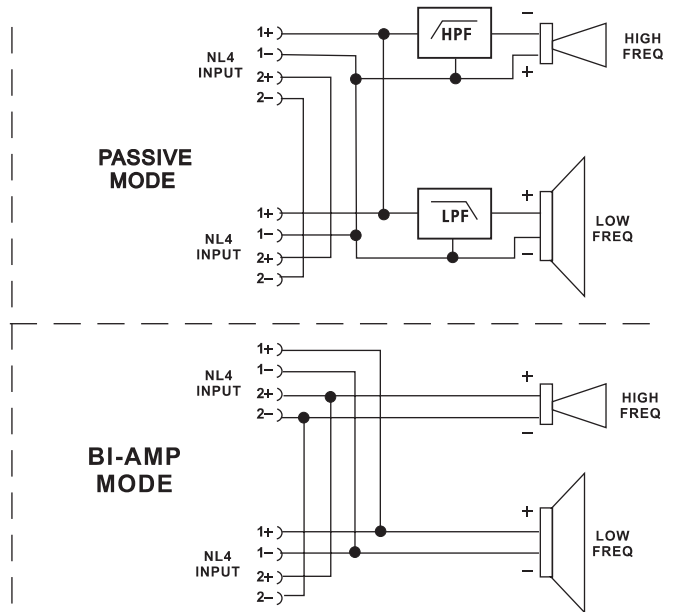
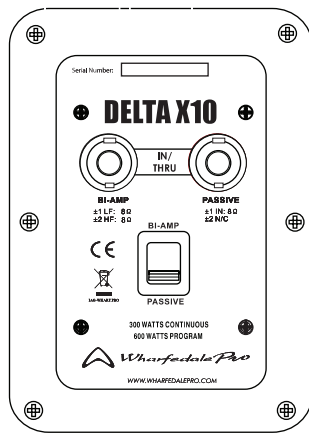

DELTA X12

Crossover Block Diagram

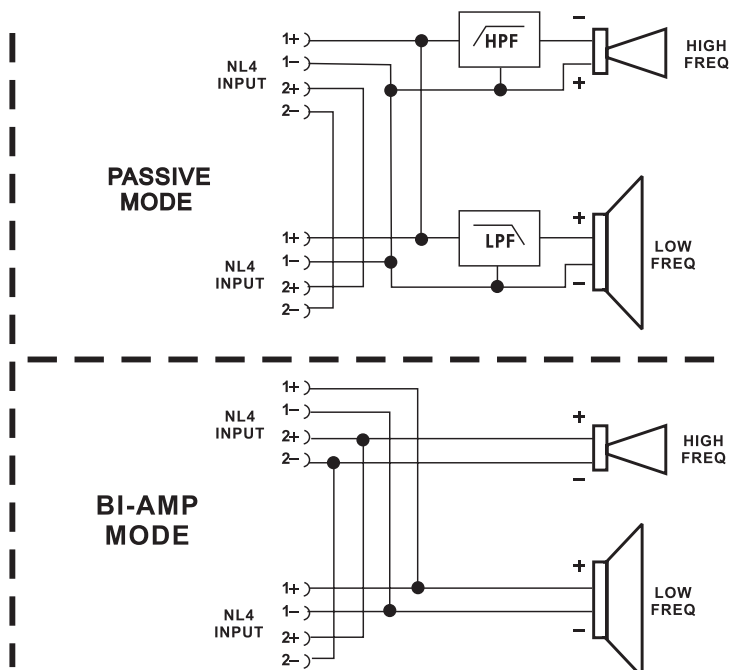
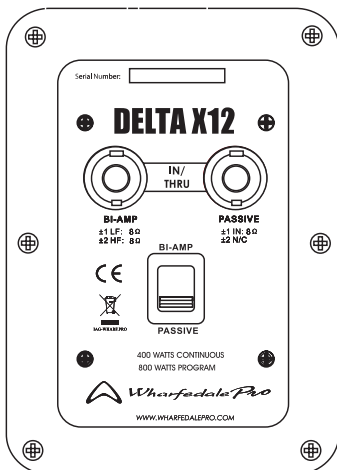

DELTA X15 Crossover Block Diagram

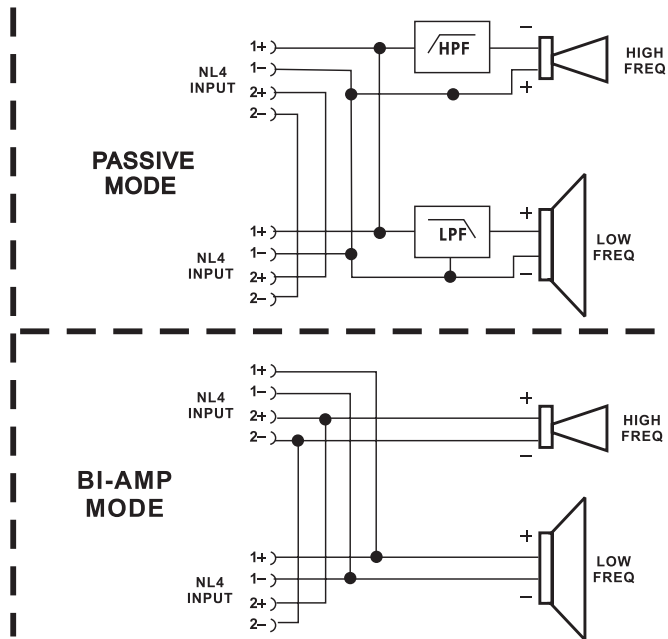
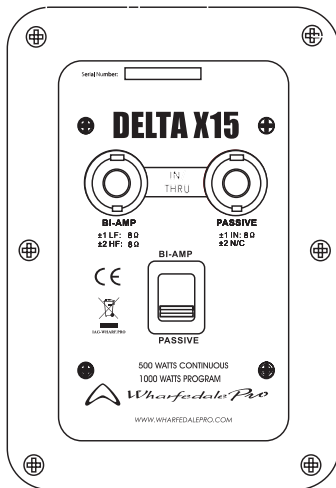

DELTA X12M Crossover Block Diagram

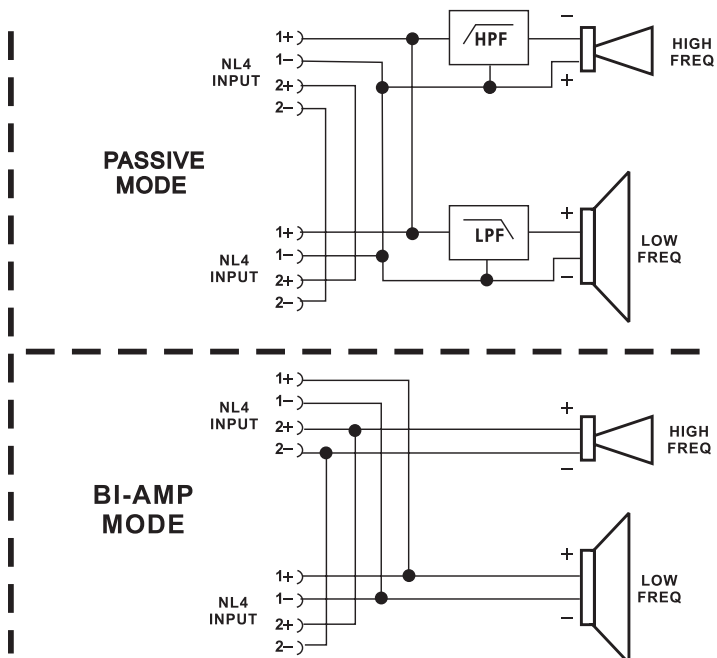
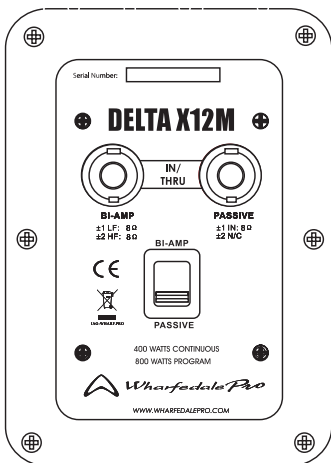

DELTA X15M Crossover Block Diagram

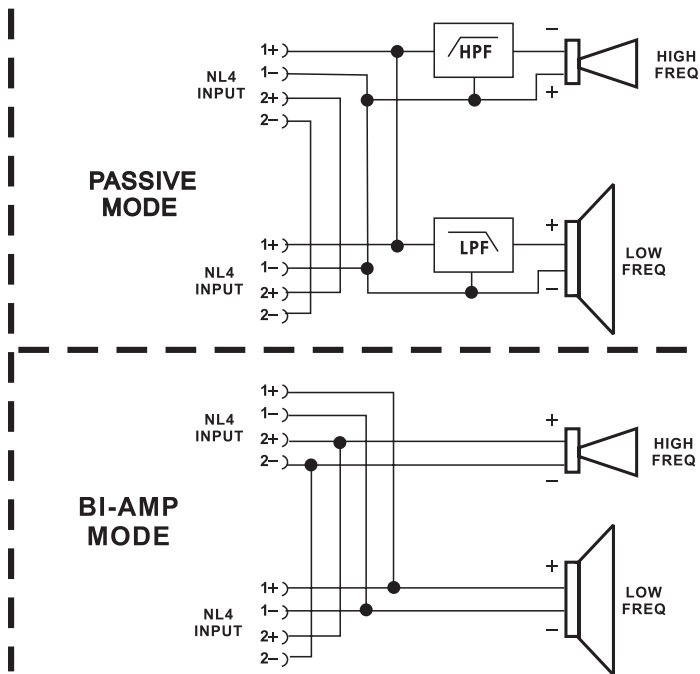
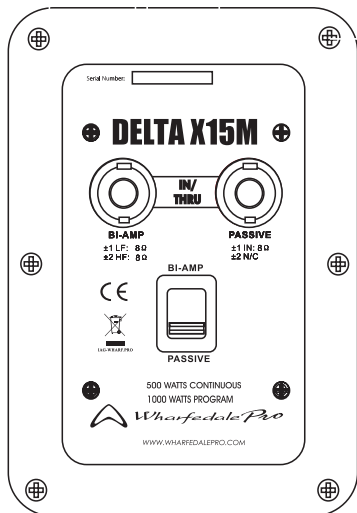

DELTA X215 Crossover Block Diagram

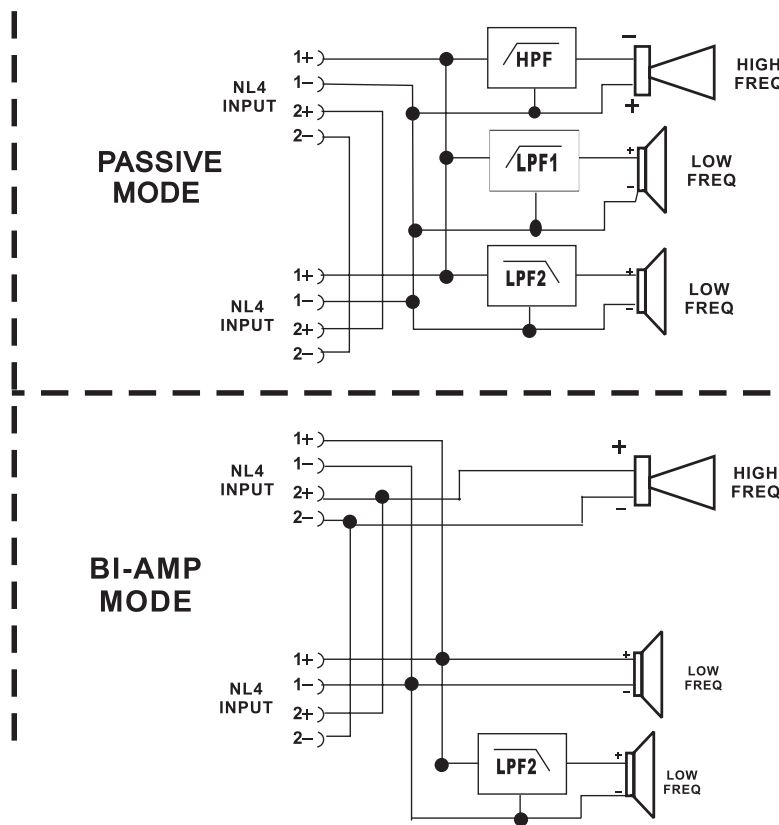

**DELTA X15B
Crossover Block Diagram**

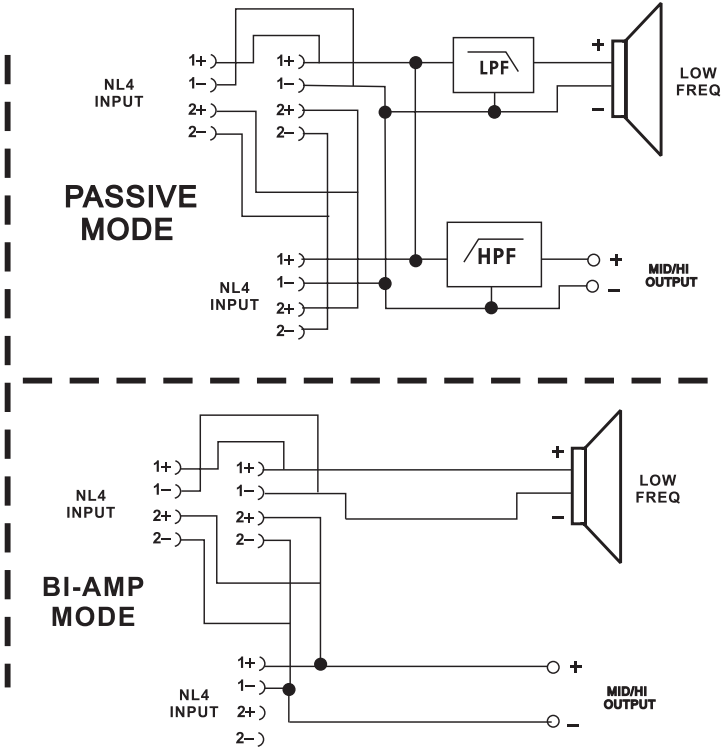
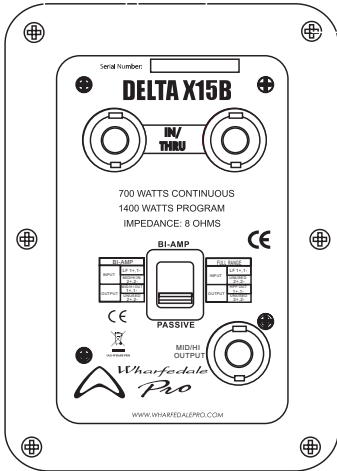

DELTA X18B Crossover Block Diagram

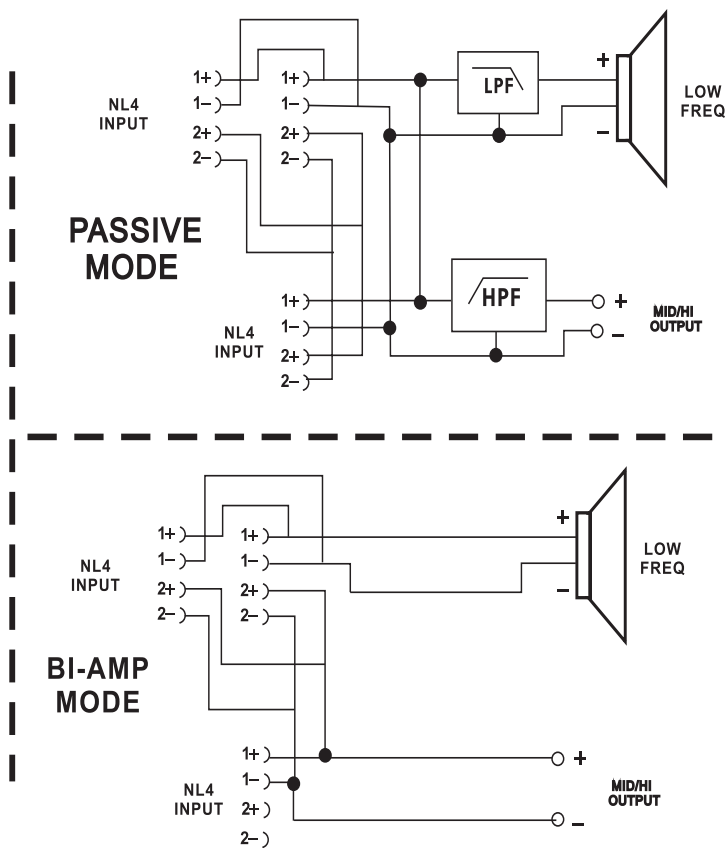
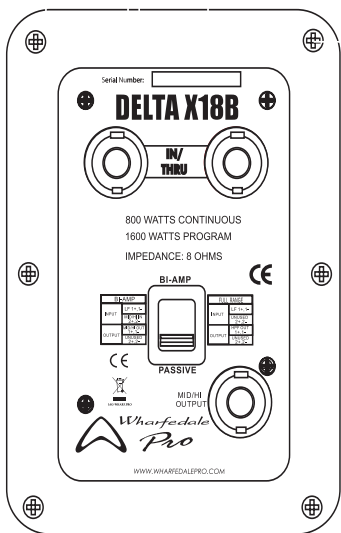

DELTA X218B
Crossover Block Diagram

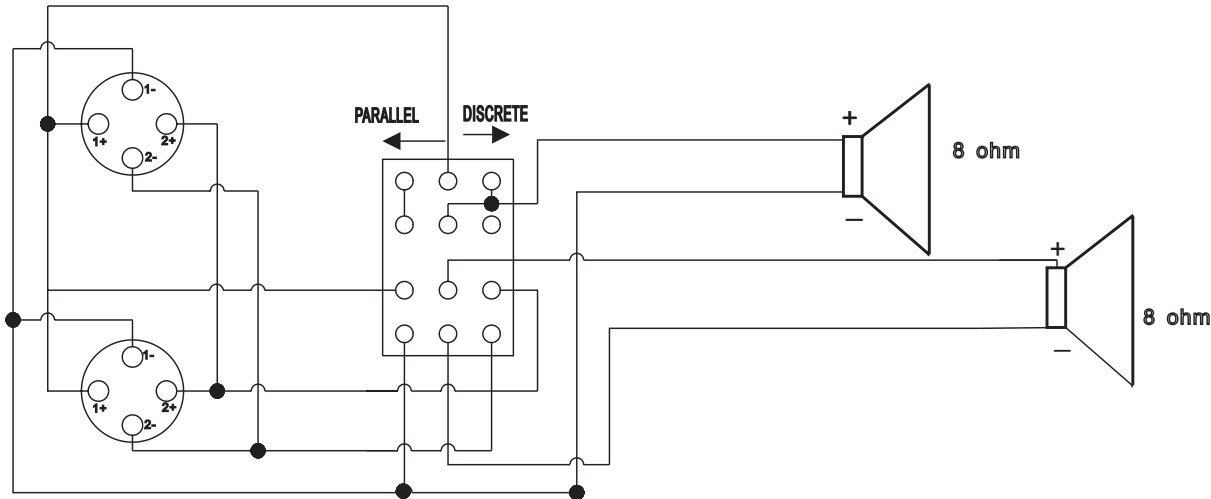
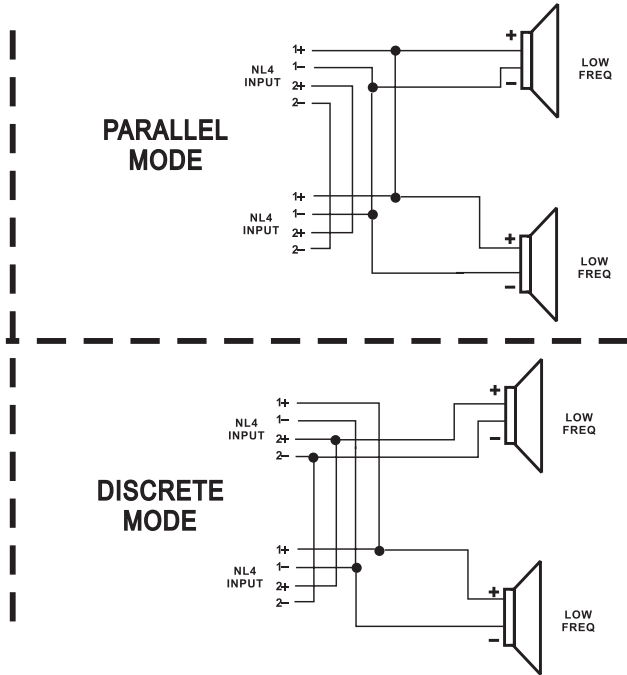
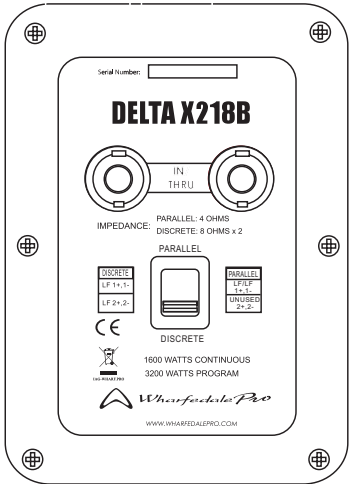

DIMENSIONAL DRAWINGS

DELTA X10

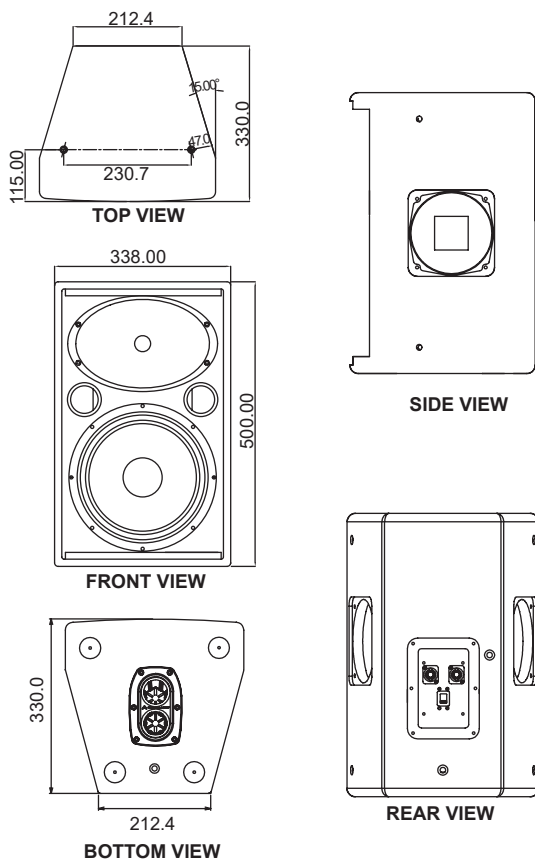

DELTA X12

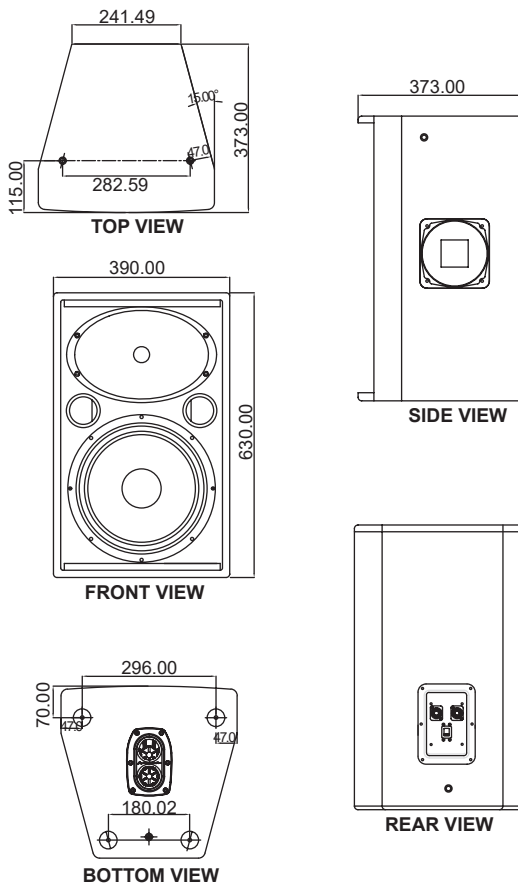

DELTA X15

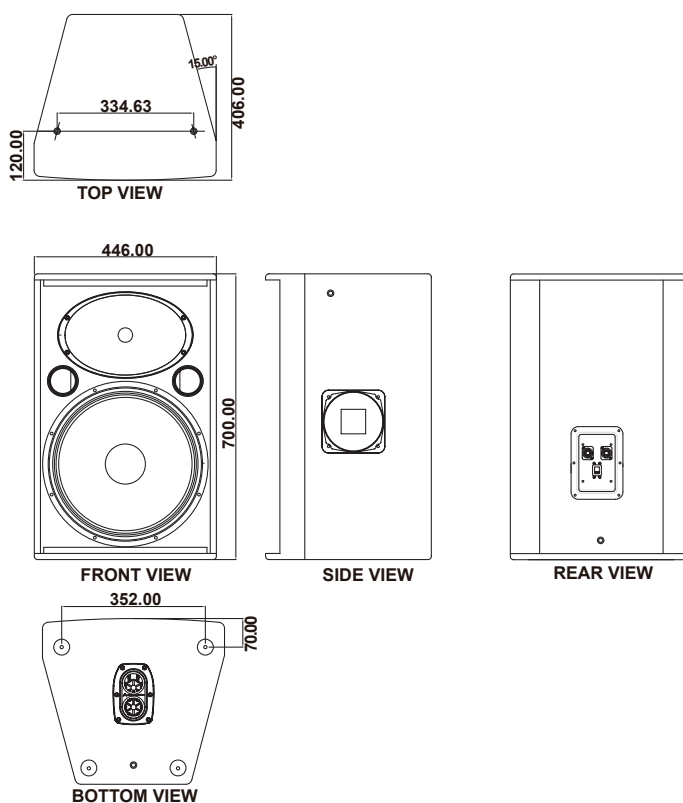

DELTA X12M

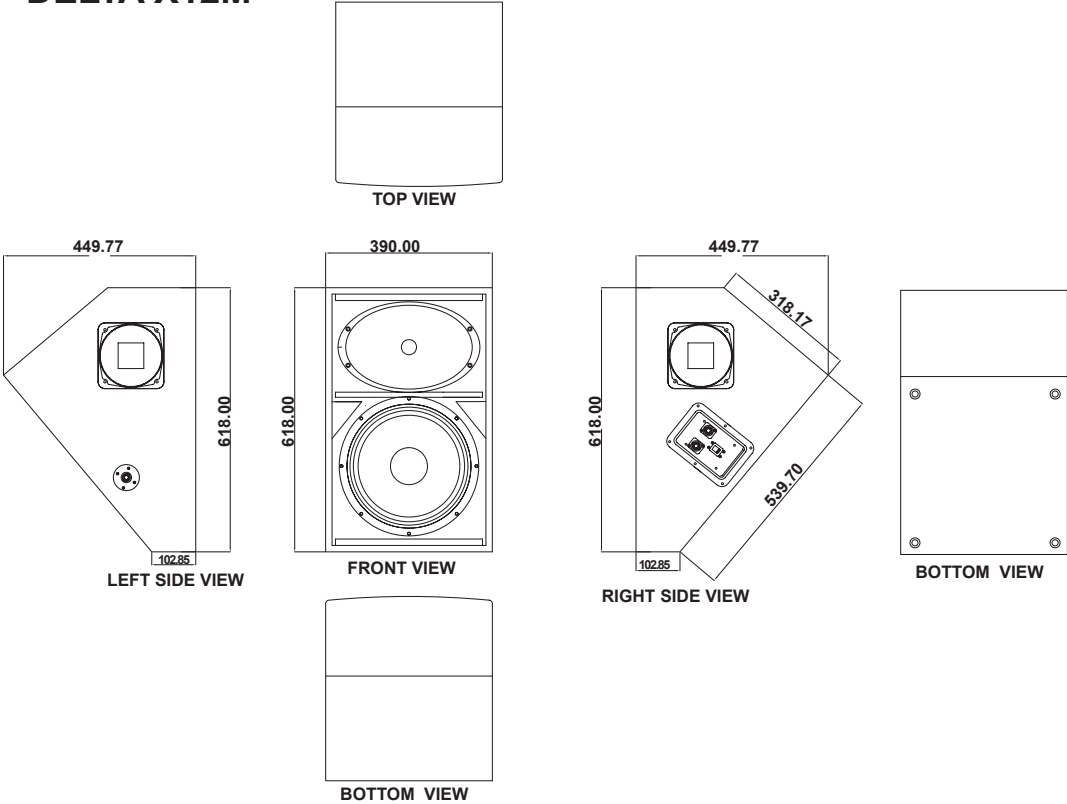

DELTA X15M

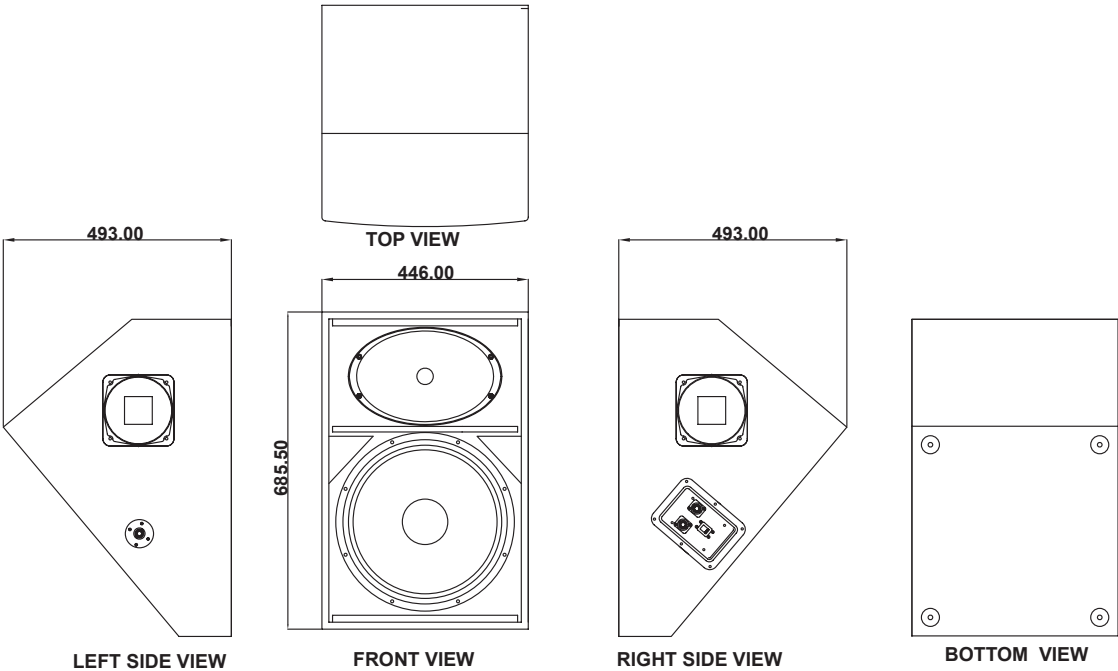

DELTA X215

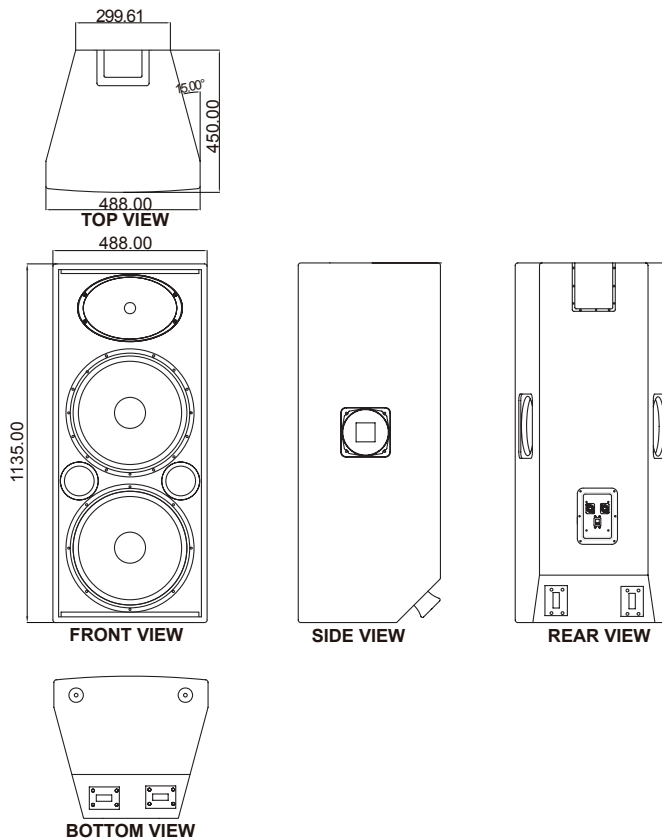

DELTA X15B

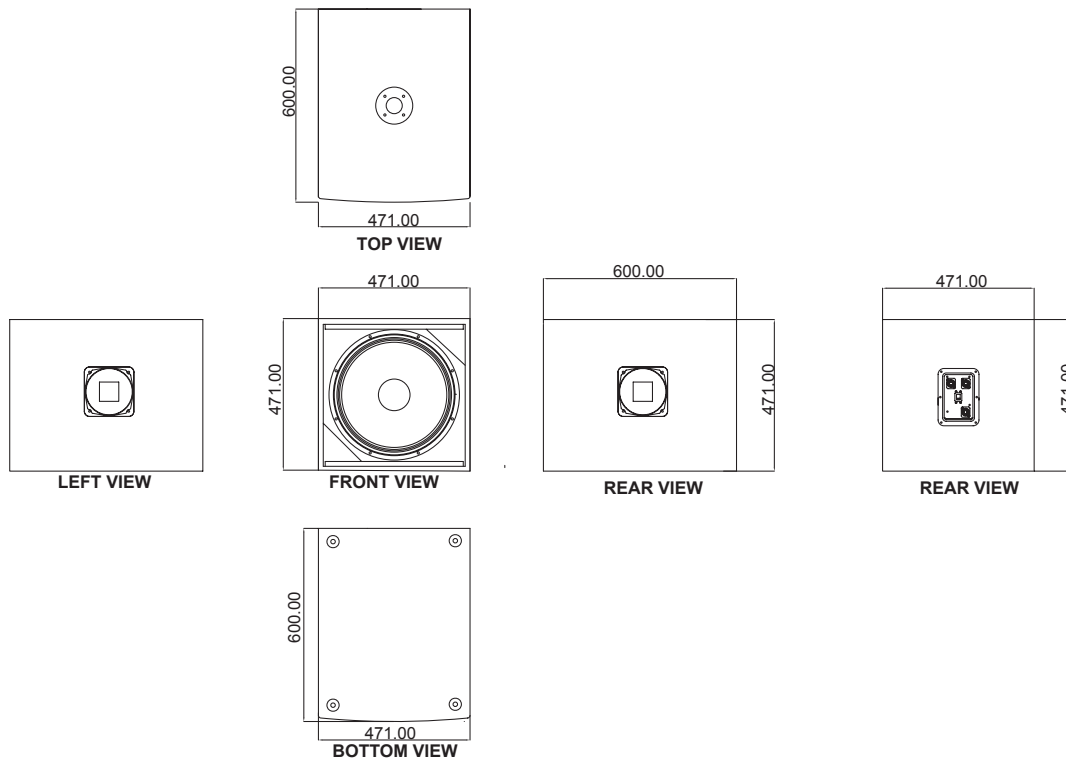

DELTA X18B

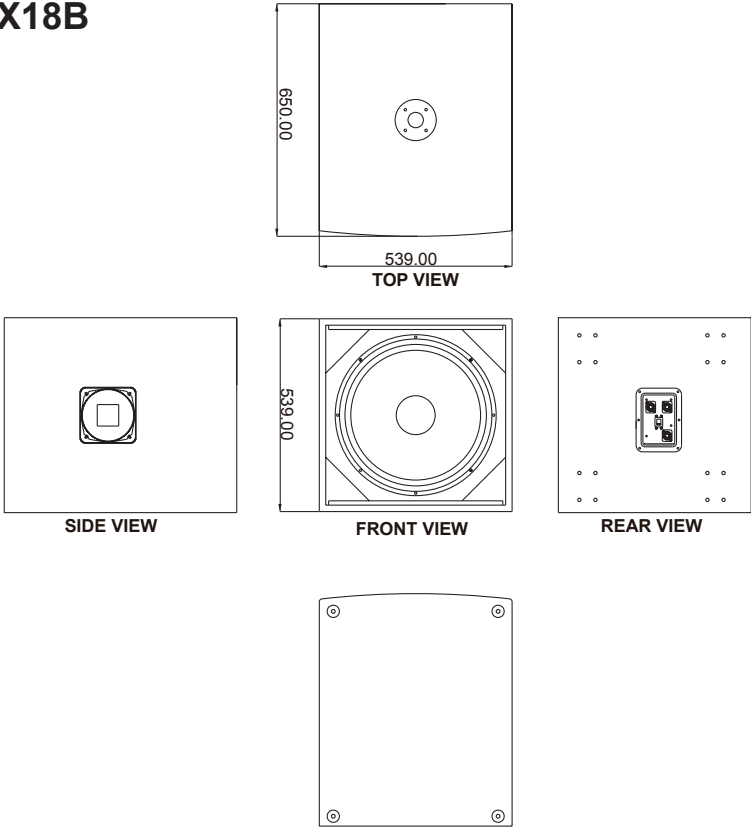

DELTA X218B

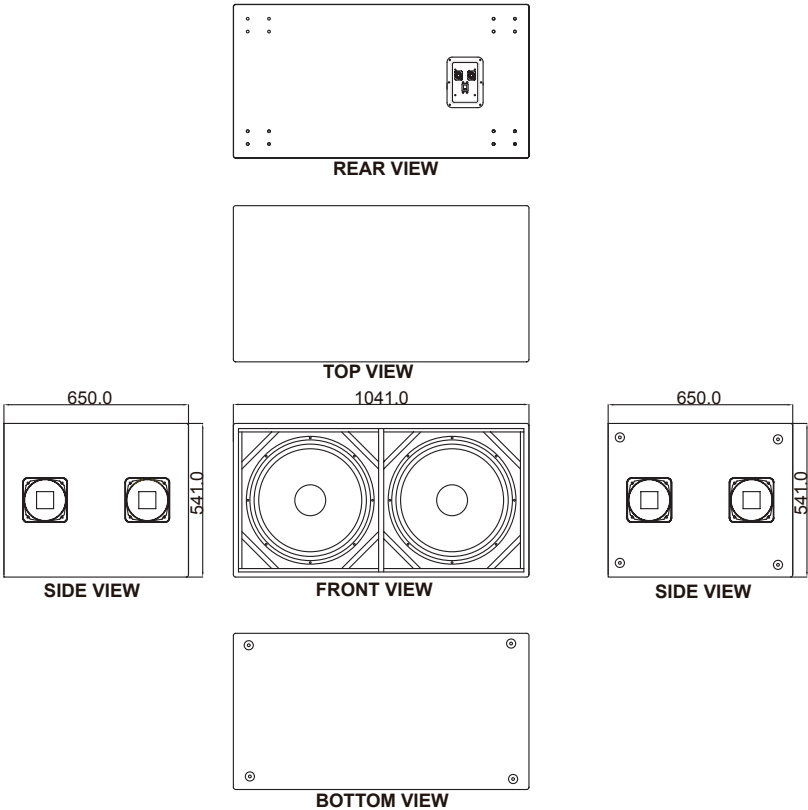

SPECIFICATIONS

Model Name	Delta X10	Delta X12	Delta X15
System Type	Passive	Passive	Passive
Configuration	Two-way	Two-way	Two-way
Frequency Response (+/-3 dB)	65 Hz-20 kHz	60 Hz-20 kHz	50 Hz-20 kHz
Frequency Range (-10 dB)	60 Hz-20 kHz	55 Hz-20 kHz	45 Hz-20 kHz
Sensitivity (2.83 v / 1 m)	97 dB	97 dB	98 dB
Calculated Maximum SPL @1 m	128 dB	129 dB	131 dB
System Rated Impedance	8 Ω	8 Ω	8 Ω
Low Frequency Transducer			
Size	288 mm / 10"	332 mm / 12"	404 mm / 15"
Voice Coil Size	63.5 mm / 2.5"	77.1 mm / 3"	77.1 mm / 3"
Rated Impedance	8 Ω	8 Ω	8 Ω
LF Power (re:AES2-2012)	300 w	400 w	500 w
High Frequency Transducer			
HF Driver Type	Compression Driver	Compression Driver	Compression Driver
Voice Coil Size	44.5 mm / 1.75" Titanium	50.8 mm / 2" Titanium	50.8 mm / 2" Titanium
Exit Size	25.4 mm / 1"	35.6 mm / 1.4"	35.6 mm / 1.4"
Diaphragm Material	Titanium	Titanium	Titanium
Rated Impedance	8 Ω	8 Ω	8 Ω
HF Power (re:AES2-2012)	40 w	50 w	50 w
Nominal Coverage (H x V)	90° x 60°	90° x 45°	90° x 45°
Power			
System Continuous Power	300 w	400 w	500 w
System Programme Power	600 w	800 w	1000 w
System Peak Power	1200 w	1600 w	2000 w
Crossover frequency	2.8 kHz	1.8 kHz	1.8 kHz
Input Connector	2 x NL4 (speakON Compatible)	2 x NL4 (speakON Compatible)	2 x NL4 (speakON Compatible)
Hardware			
Pole Mount	Dual Angle (0°/10°) 35 mm	Dual Angle (0°/10°) 35 mm	Dual Angle (0°/10°) 35 mm
Handles	2 on Sides	2 on Sides	2 on Sides
Enclosure			
Enclosure Material	15 mm Plywood	15 mm Plywood	15 mm Plywood
Finish	Rhino Rock	Rhino Rock	Rhino Rock
Grille Material & Finish	1.5 mm Steel Black or White	1.5 mm Steel Black	1.5 mm Steel Black
Dimensions - Unpacked			
Height	500 mm / 19.7"	630 mm / 24.8"	700 mm / 27.6"
Width Front	338 mm / 13.3"	390 mm / 15.3"	446 mm / 17.6"
Width Rear	212.4 mm / 8.4"	241.2 mm / 9.5"	281.4 mm / 11.1"
Depth	330 mm / 13"	373 mm / 14.7"	406 mm / 16.0"
Dimensions - Packed			
Height	575 mm / 22.6"	773 mm / 28.9"	803 mm / 31.6"
Width Front	400 mm / 15.7"	566 mm / 22.3"	622 mm / 24.5"
Width Rear	300 mm / 11.8"	566 mm / 22.3"	622 mm / 24.5"
Depth	386 mm / 15.2"	464 mm / 18.3"	498 mm / 19.6"
Weight			
Net Weight (kg / lbs)	16.58 kg / 36.5 lbs	24.7 kg / 54.5 lbs	29.9 kg / 65.9 lbs
Gross Weight (kg / lbs)	19.6 kg / 43.0 lbs	29 kg / 63.8 lbs	35.5 kg / 78.1 lbs

SPECIFICATIONS

Model Name	Delta X12M	Delta X15M	Delta X215
System Type	Passive	Passive	Passive
Configuration	Two-way	Two-way	Quasi Three-way
Frequency Response (+/-3 dB)	60 Hz-20 kHz	55 Hz-20 kHz	45 Hz-20 kHz
Frequency Range (-10 dB)	55 Hz-20 kHz	50 Hz-20 kHz	40 Hz-20 kHz
Sensitivity (2.83 v / 1 m)	97 dB	98 dB	101 dB
Calculated Maximum SPL @1 m	129 dB	131 dB	137 dB
System Rated Impedance	8 Ω	8 Ω	4 Ω
Low Frequency Transducer			
Size	332 mm / 12"	404 mm / 15"	2 x 404 mm / 15"
Voice Coil Size	77.1 mm / 3"	77.1 mm / 3"	77.1 mm / 3"
Rated Impedance	8 Ω	8 Ω	2 x 8 Ω
LF Power (re:AES2-2012)	400 w	500 w	2 x 500 w
High Frequency Transducer			
HF Driver Type	Compression Driver	Compression Driver	Compression Driver
Voice Coil Size	50.8 mm / 2" Titanium	50.8 mm / 2" Titanium	50.8 mm / 2"
Exit Size	35.6 mm / 1.4"	35.6 mm / 1.4"	35.6 mm / 1.4"
Diaphragm Material	Titanium	Titanium	Titanium
Rated Impedance	8 Ω	8 Ω	8 Ω
HF Power (re:AES2-2012)			50 w
Nominal Coverage (H x V)			90° x 45°
Power			
System Continuous Power	400 w	500 w	1000 w
System Programme Power	800 w	1000 w	2000 w
System Peak Power	1600 w	2000 w	4000 w
Crossover frequency	1.8 kHz	1.8 kHz	1.8 kHz
Input Connector	2 x NL4 (speakON Compatible)	2 x NL4 (speakON Compatible)	2 x NL4 (speakON Compatible)
Hardware			
Pole Mount			
Handles	2 on Sides	2 on Sides	2 on Sides / 1 on Back
Enclosure			
Enclosure Material	15 mm Plywood	15 mm Plywood	15 mm Plywood
Finish	Rhino Rock	Rhino Rock	Rhino Rock
Grille Material & Finish	1.5 mm Steel Black	1.5 mm Steel Black	1.5 mm Steel Black
Dimensions - Unpacked			
Height	449 (SITU)mm / 17.7"	493 (SITU)mm / 19.4"	1135 mm / 44.7"
Width Front	390 mm / 15.4"	446 mm / 17.6"	488 mm / 19.2"
Width Rear	390 mm / 15.4"	446 mm / 17.6"	299.6 mm / 11.8"
Depth	618 mm / 24.3"	685 mm / 27.0"	450 mm / 17.7"
Dimensions - Packed			
Height	462 mm / 18.2"	518 mm / 20.4"	1218 mm / 48.0"
Width Front	690 mm / 27.2"	757 mm / 29.8"	558 mm / 22.0"
Width Rear	690 mm / 27.2"	757 mm / 29.8"	558 mm / 22.0"
Depth	522 mm / 20.6"	565 mm / 22.2"	522 mm / 20.6"
Weight			
Net Weight (kg / lbs)	23.18 kg / 50.9 lbs	27.24 kg / 59.9 lbs	52.9 kg / 116.6 lbs
Gross Weight (kg / lbs)	28.5 kg / 62.7 lbs	33.96 kg / 74.7 lbs	59.0 kg / 130.0 lbs

SPECIFICATIONS

Model Name	Delta X15B	Delta X18B	Delta X218B
System Type	Passive	Passive	Passive
Configuration	Subwoofer	Subwoofer	Dual Chamber Subwoofer
Frequency Response (+/-3 dB)	42 Hz -2 KHz(BI-AMP)	38 Hz-1.5 KHz(BI-AMP)	30 Hz -1.5 KHz
Frequency Range (-10 dB)	38 Hz-150 Hz	30 Hz-1.5 KHz	25 Hz -1.5 kHz
Sensitivity (2.83 v / 1 m)	98 dB	99 dB	100 dB
Calculated Maximum SPL @1 m	132 dB	134 dB	138 dB
System Rated Impedance	8 Ω	8 Ω	Parallel: 4 Ω Discrete: 8 Ω x 2
Low Frequency Transducer			
Size	404 mm / 15"	470 mm / 18"	470 mm / 18"
Voice Coil Size	102 mm / 4"	102 mm / 4"	102 mm / 4"
Rated Impedance	8 Ω or 4 Ω	8 Ω or 4 Ω	2 x 8 Ω
LF Power (re:AES2-2012)	700 w	800 w	2 x 800 w
High Frequency Transducer			
HF Driver Type			
Voice Coil Size			
Exit Size			
Diaphragm Material			
Rated Impedance			
HF Power (re:AES2-2012)			
Nominal Coverage (H x V)			
Power			
System Continuous Power	700 w	800 w	1600 w Parallel / 800 w Discrete
System Programme Power	1400 w	1600 w	3200 w Parallel / 1600 w Discrete
System Peak Power	2800 w	3200 w	6400 w Parallel / 3200 w Discrete
Crossover frequency			
Input Connector	2 x NL4 (speakON Compatible)	2 x NL4 (speakON Compatible)	2 x NL4 (speakON Compatible)
Hardware			
Pole Mount	35 mm	35 mm	
Handles	2 on Sides	2 on Sides	4 on Sides
Enclosure			
Enclosure Material	15 mm Plywood	15 mm Plywood	18 mm Plywood
Finish	Rhino Rock	Rhino Rock	Rhino Rock
Grille Material & Finish	1.5 mm Steel Black	1.5 mm Steel Black	1.5 mm Steel Black
Dimensions - Unpacked			
Height	471 mm / 18.5"	539 mm / 21.2"	541 mm / 21.3"
Width Front	471 mm / 18.5"	539 mm / 21.2"	1041 mm / 41.0"
Width Rear	471 mm / 18.5"	539 mm / 21.2"	1041 mm / 41.0"
Depth	600 mm / 23.6"	650 mm / 25.6"	650 mm / 25.6"
Dimensions - Packed			
Height	556 mm / 21.9"	624 mm / 24.6"	626 mm / 25.6"
Width Front	543 mm / 21.4"	611 mm / 24.1"	1126 mm / 44.3"
Width Rear	543 mm / 21.4"	611 mm / 24.1"	1126 mm / 44.3"
Depth	672 mm / 26.5"	722 mm / 28.4"	722 mm / 28.4"
Weight			
Net Weight (kg / lbs)	31.5 kg / 69.4 lbs	37.3 kg / 82.06 lbs	78.9 kg / 173.9 lbs
Gross Weight (kg / lbs)	35.12 kg / 77.4 lbs	43.2 kg / 95.04 lbs	86.0 kg / 189.6 lbs

WHARFEDALE PRO LIMITED WARRANTY

Wharfedale Pro products are warranted of manufacturing or material defects for a period of one year from the original date of purchase. In the event of malfunction, contact your authorized Wharfedale Pro dealer or distributor for information.

*Be aware that warranty details may differ from country to country. Contact your dealers or distributor for information. These terms do not infringe your statutory rights.



Wharfedale Professional

IAG House, 13/14 Glebe Road, Huntingdon, Cambridgeshire, PE29 7DL, UK

www.wharfedalepro.com

Wharfedale Professional reserves the right to alter or improve specifications without notice.
All rights reserved © 2021 Wharfedale Pro. Wharfedale Pro is a member of the IAG Group.