

PROFESSIONAL SOUND SYSTEMS >>>

# FOCUS Series

## OPERATING MANUAL AND USER GUIDE

FOCUS-12 FOCUS-15 FOCUS-18S FOCUS-218S



[www.wharfedalepro.com](http://www.wharfedalepro.com)

# TABLE OF CONTENTS

1. IMPORTANT WARNINGS & SAFETY INSTRUCTIONS.....	1
2. INTRODUCTION.....	2
3. FOCUS SERIES OVERVIEW.....	2
4. INSTALLATION.....	3
5. FOCUS HANGING INSTALLATION INSTRUCTIONS.....	3
6. FOCUS-12/15 BLOCK DIAGRAM.....	5
7. FOCUS-18S/218S BLOCK DIAGRAM.....	6
8. FOCUS-12/15 BI-AMP WIRING.....	7
9. FOCUS-12/15 FULLRANGE WIRING.....	8
10. FOCUS-12/15 POLAR GRAPHS.....	9
11. SPECIFICATIONS.....	13
12. WARRANTY.....	BACK COVER

# IMPORTANT WARNINGS & SAFETY INSTRUCTIONS

1. READ ALL INSTRUCTIONS – Carefully and become familiar with the features and functions of these products before operating them.
2. RETAIN THESE INSTRUCTIONS – For future reference.
3. COMPLY WITH ALL WARNINGS – Non compliance may void warranty of the product.
4. USE WITH AMPLIFIERS – In order to avoid damage to drivers and other equipment, it is advisable to establish and follow a routine for powering up and powering down a sound system. With all system components connected, turn on source equipment (mixers, signal processors, record and playback units etc.) BEFORE powering up amplifiers. Transient voltages from powering up source equipment can damage speakers if amplifiers are already turned on. Make sure that amplifier volumes are set to their minimum settings and power up any system amplifiers LAST. It is recommended that all system components be allowed to stabilize for few seconds before any source signals are introduced or level setting adjustments are made. Similarly, when shutting systems down, turn all amplifiers off first, before powering down any other system components.
5. CABLES – Do not use shielded or microphone cables for connection between amplifiers and speakers. Use only approved speaker cables with proper connectors.
6. RIGGING – SUSPENDING – MOUNTING – RIGGING, Suspending and mounting of these speaker systems can expose members of the public to serious health risks and even death. Under no circumstances attempt to rig, suspend or otherwise mount these speakers unless you are fully qualified and certified to do so by relevant local, state and national authorities. All relevant safety regulations must be followed. If you are not properly qualified or do not know of pertinent regulations, consult qualified personnel for advice.
7. CAUTION – These professional loudspeaker systems are capable of generating very high sound pressure levels. Use care with placement and operation to avoid exposure to excessive volume levels. Permanent hearing damage can result when operated to extreme levels.
8. SERVICE – There are no user serviceable parts inside this product. Users should not attempt to service this product. Warranty nullification could result if this is attempted.

# **INTRODUCTION**

Wharfedale Pro Focus Series loudspeakers are the result of many years of experience in the use, design and manufacture of professional loudspeaker products. We take great pride in engineering and building every Wharfedale Pro loudspeaker and would like to thank you for entrusting us with your sound solutions.

## **FOCUS SERIES OVERVIEW**

### **Music to the masses**

With the Wharfedale Pro Focus point-source array system you now have a solution that provides not just exceptional quality sound but also a flexible cabinet and hardware configuration enabling you to meet the requirements of a wide variety of venues. Focus' easy adaptability makes it perfect for portable rentals, touring and stage shows.

### **Optimised acoustic engineering**

The Focus family has 4 components to choose from - a 12" and 15" PA and a 18" and twin 18" subwoofer. Focus tops and subs are superbly engineered to work together seamlessly and provide maximum efficiency. The two-way PA speakers employ a High-Q 100° x 10° long-throw waveguide horn geometry to project the sound au the way to the back of large listening areas. All this comes together to create a point-source array system!

### **Meets your needs**

Focus hardware allows you to fly in a line-array configuration, fly independently and in pairs or stack PA's on top of subs. Focus adapts perfectly to whatever challenges your venue presents you with!

### **Sonic Impact**

At peak output a single Focus-15 can pump out 135db SPL; maximum power handling is rated at 2800 watts peak. Focus subs put out an equally impressive 146dB peak SPL of pounding bass with a maximum power handling capacity of 8000 watts peak. Need more? Just double up! The Focus V-Tech side-by-side driver placement maximizes mutual coupling and boundary-effect reinforcement to move massive amounts of air and push the beat to the soul of your audience.

# INSTALLATION

- Before attempting to install a FOCUS Series loudspeaker system please refer to the important warnings and safety instructions. Only qualified personnel should install a loudspeaker system.

**Improper installation of a loudspeaker system can cause serious harm and even death if correct procedure is not followed. Anyone attempting installation assumes all liability arising from such use.**

## FOCUS HANGING INSTALLATION INSTRUCTIONS

### Safe Rigging

FOCUS-12, FOCUS-15 suspendable version loudspeakers are supplied with built-in internal brackets. The system is designed to facilitate the suspension of the loudspeaker by a qualified person familiar with rigging and hardware industry practices. Improper installation may result in damage, injury or death.

### Working Load Limit

The working load limit (WLL) of any FOCUS-12, FOCUS-15 suspendable loudspeaker will be maintained as long as no more than 136kg (300 lb) is suspended by minimum of Two (2) PRIMARY SUSPENSION points (Track Suspension), or 46kg (100 lb) is suspended by TWO (2) of the SECONDARY SUSPENSION POINTS (M10 Forged Shoulder Eyebolts).

### Flying for Portable Application (Primary Suspension)

For portable, temporary suspension of FOCUS-12, FOCUS-15 Models, order the FOCUS. This kit includes four detachable fly-clips. For additional suspension components, contact a professional rigging hardware supplier.

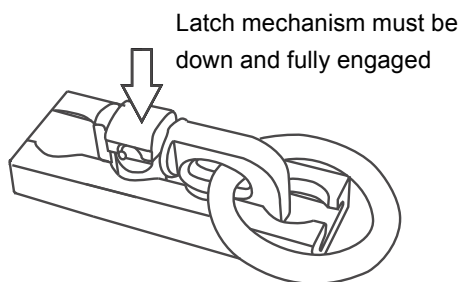

## WARNING

Before lifting any speaker using fly-clip attachments, be certain that the latch mechanism of all fly-clips is fully and properly engaged with the track. An audible click will be heard.

## Suspension in Fixed Installations (Secondary Suspension)

For fixed installations of Focus-12, focus-15 models using M10, forged-shoulder eyebolts.

### WARNING

Suspension of FOCUS-12/15 speaker must employ both top attachment points. When 'bridling' the FOCUS-12/15. Two (2) legs of equal length must be used. The rear attachment points is a pull-back point and is intended only for use in adjusting the down-angle of the speaker enclosure. Only the top and bottom attachment points are intended for use as suspension points.

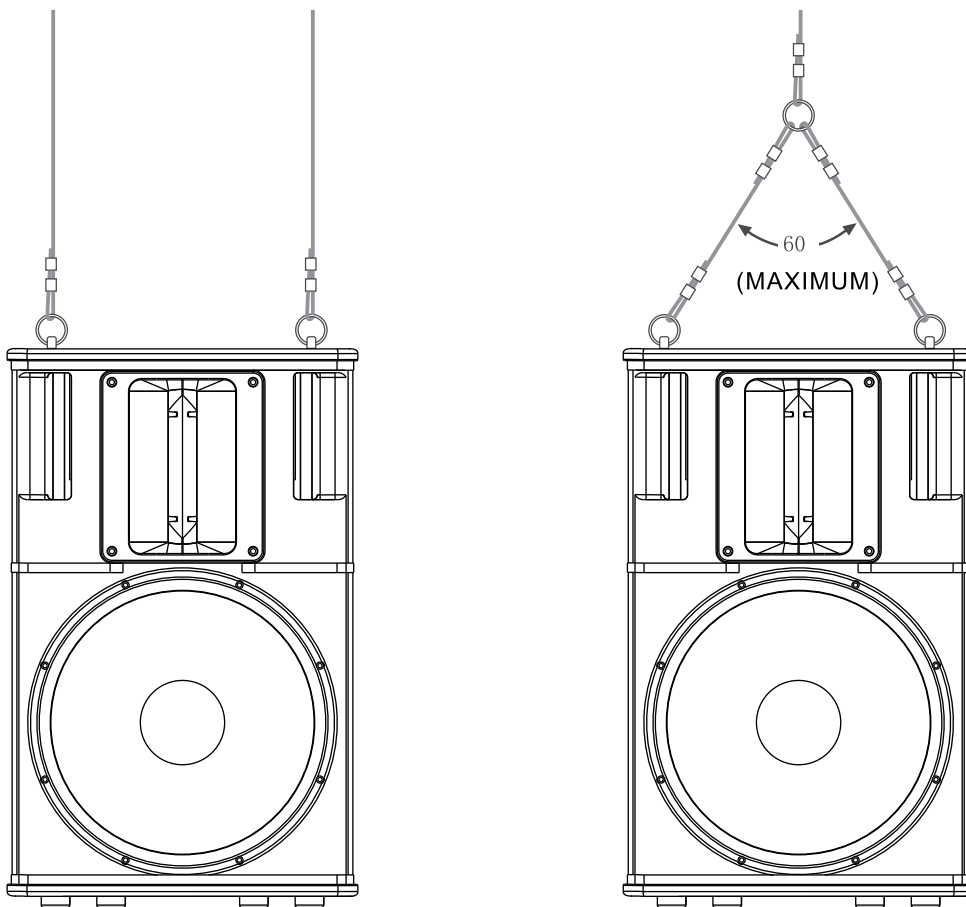

# FOCUS-12

## Block Diagram

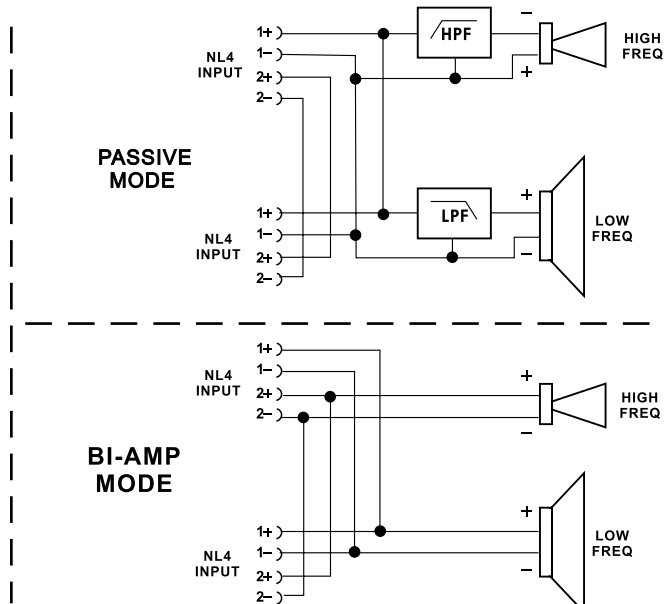
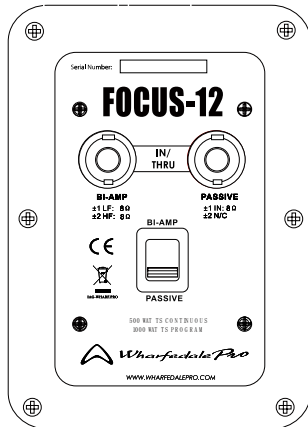

# FOCUS-15

## Block Diagram

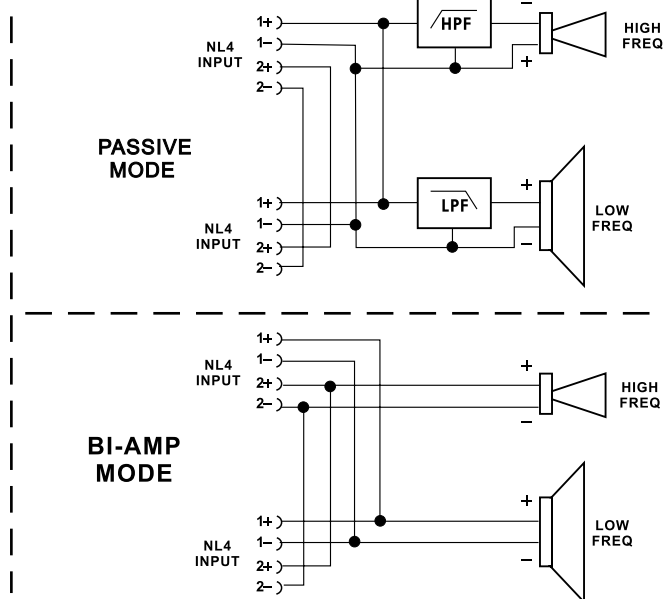
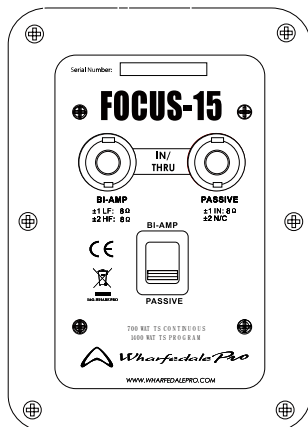

# FOCUS-18S

## Block Diagram

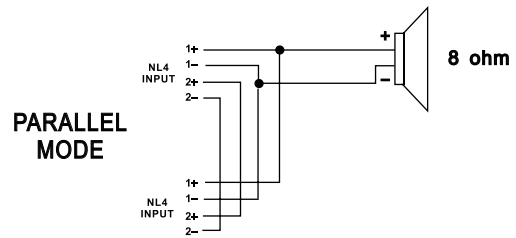
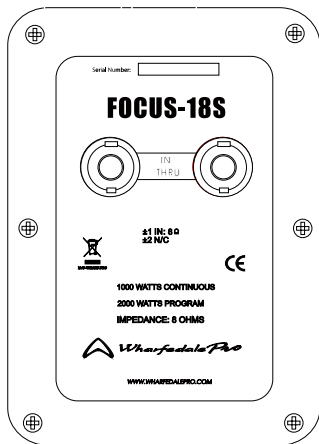

# FOCUS-218S

## Block Diagram

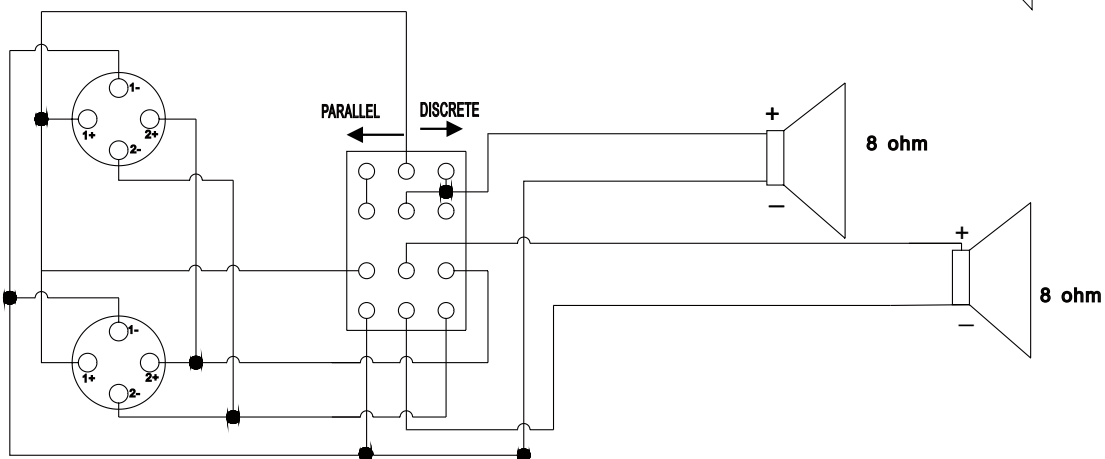
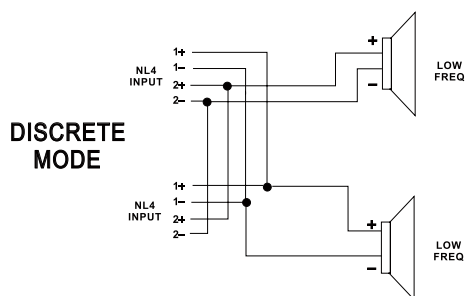
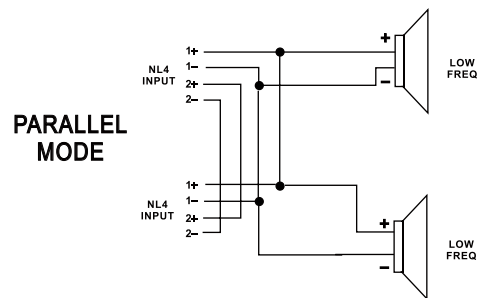
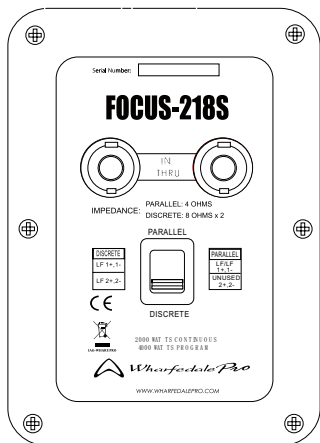



# FOCUS-12/15 BI-AMP WIRING

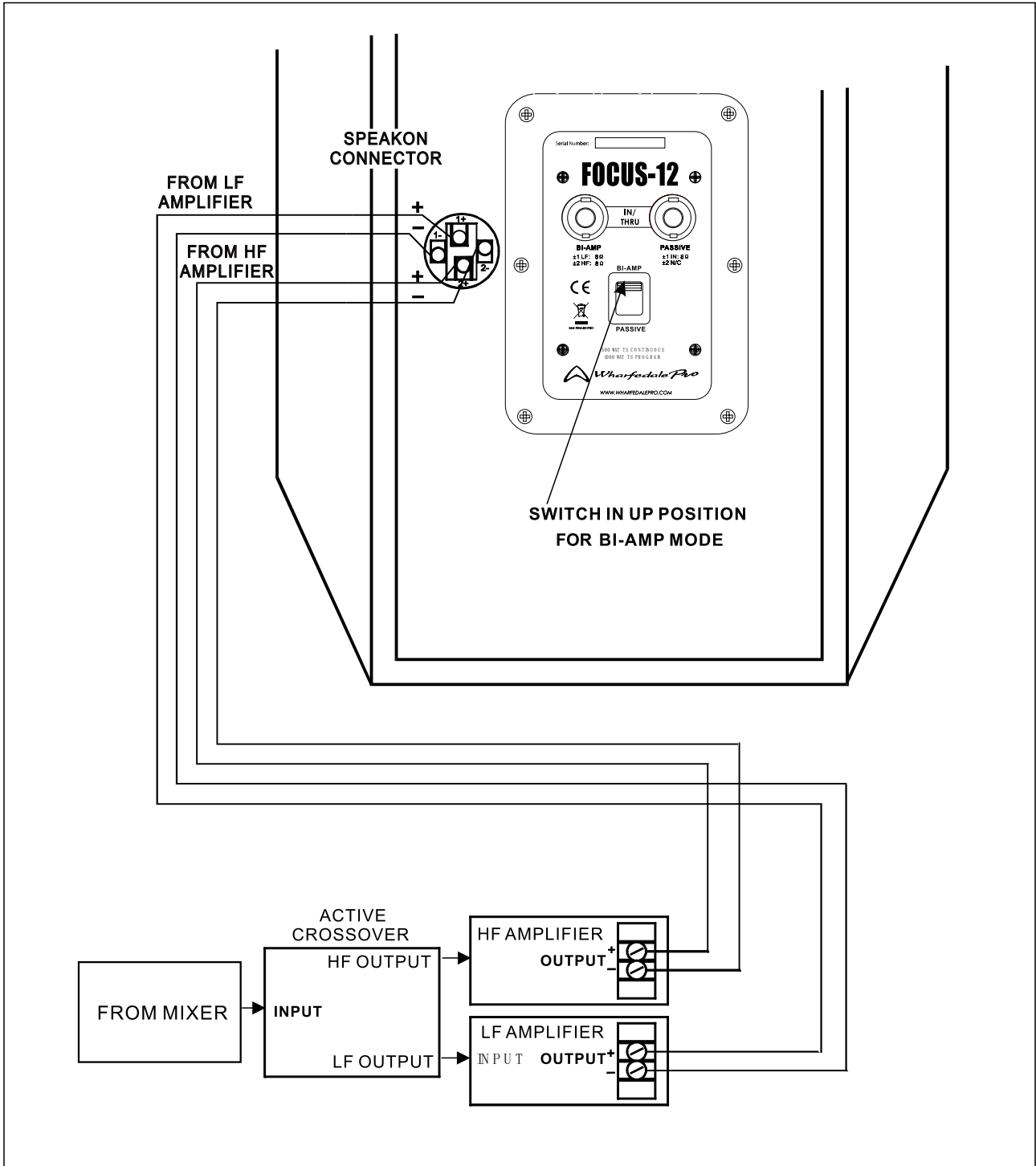

# FOCUS-12/15 FULLRANGE WIRING

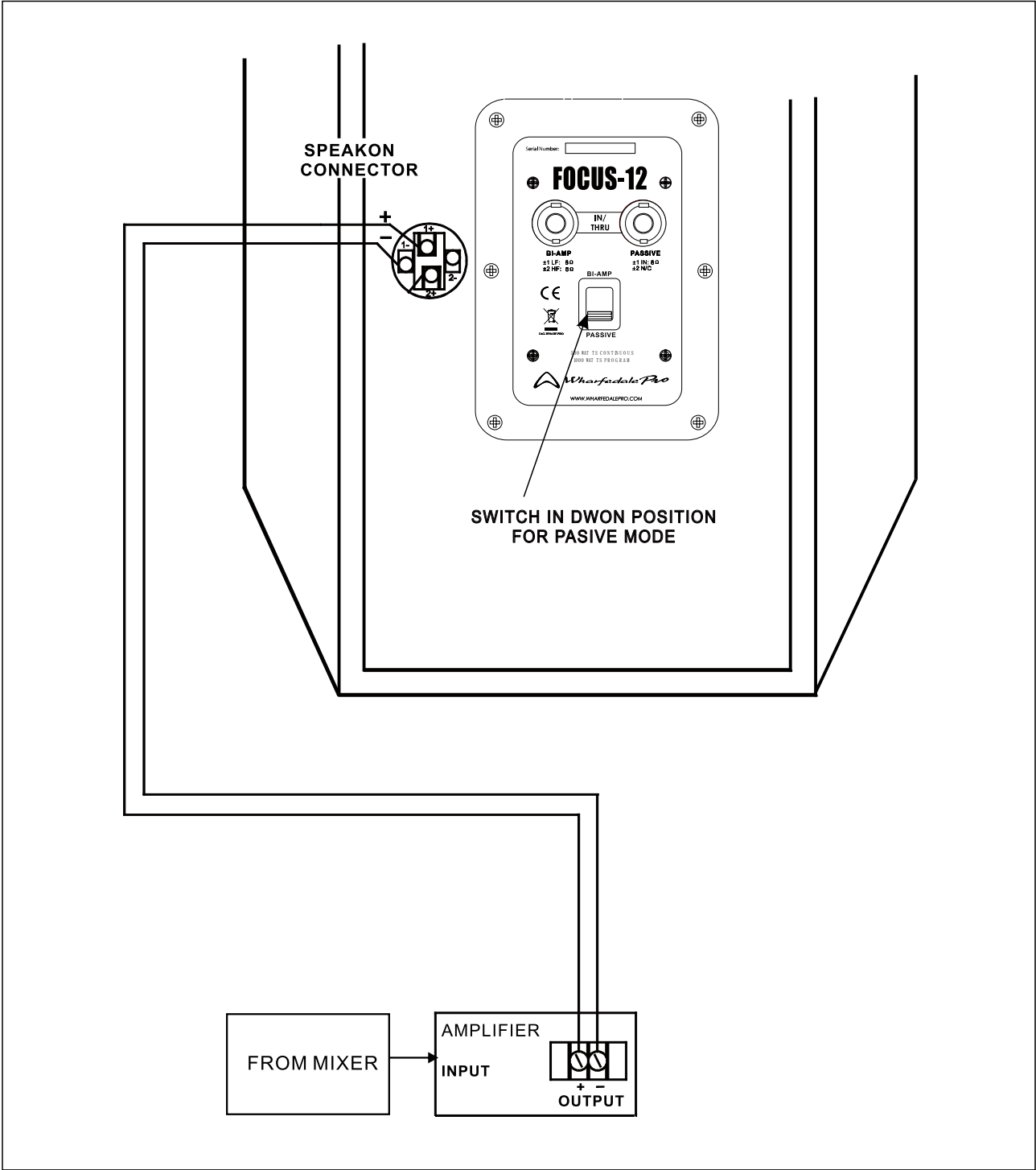

# FOCUS-12 HORIZONTAL POLAR GRAPHS

125Hz

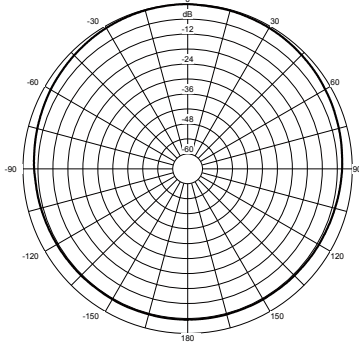

250Hz

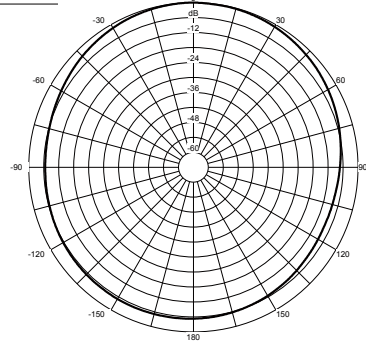

500Hz

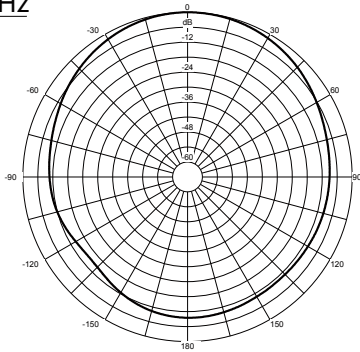

1000Hz

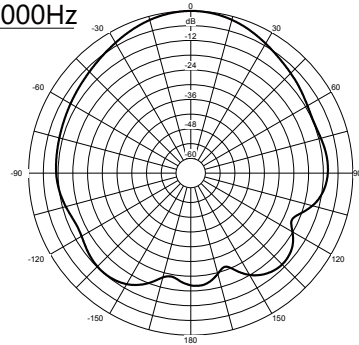

2000Hz

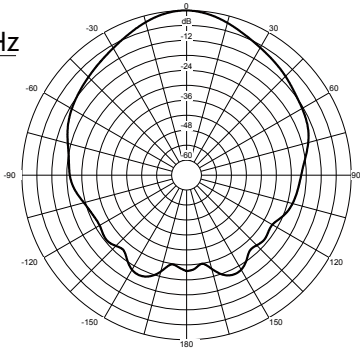

4000Hz

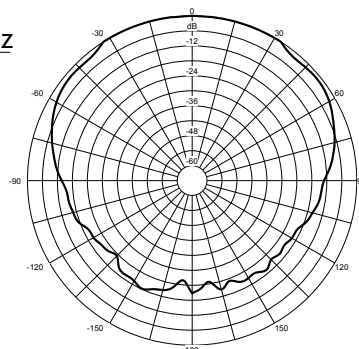

8000Hz

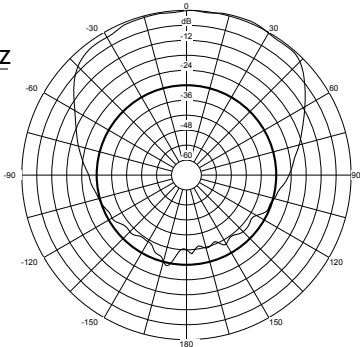

16000Hz

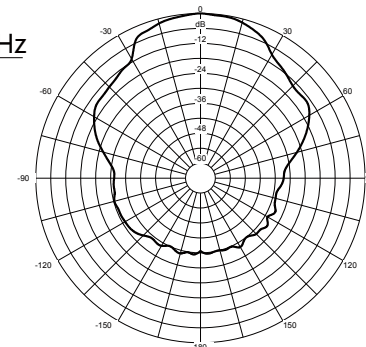

# FOCUS-12 VERTICAL POLAR GRAPHS

125Hz

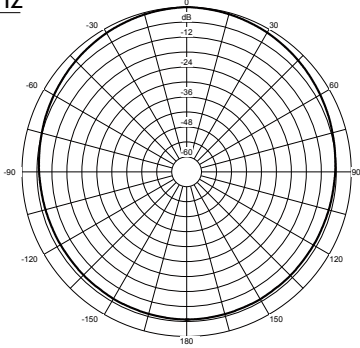

250Hz

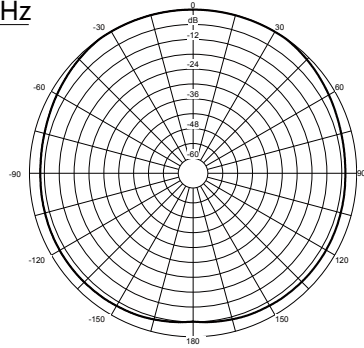

500Hz

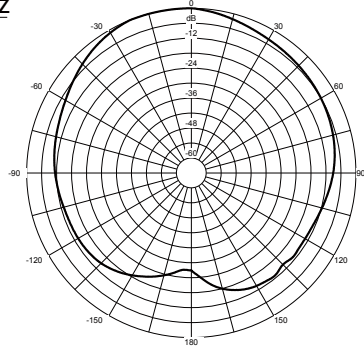

1000Hz

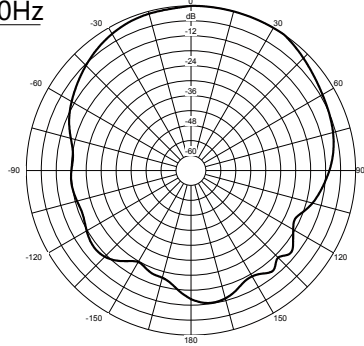

2000Hz

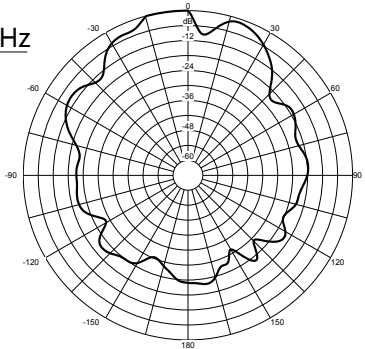

4000Hz

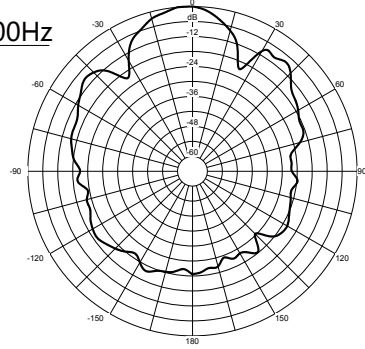

8000Hz

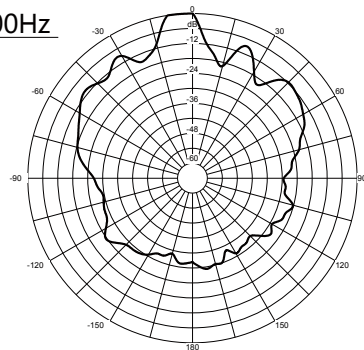

16000Hz

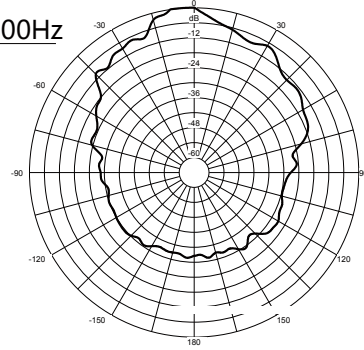

# FOCUS-15 HORIZONTAL POLAR GRAPHS

125Hz

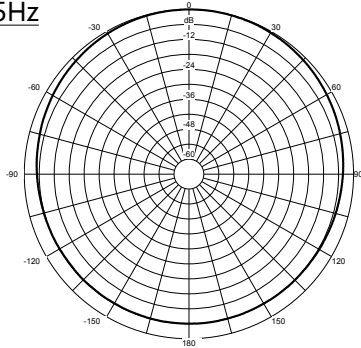

250Hz

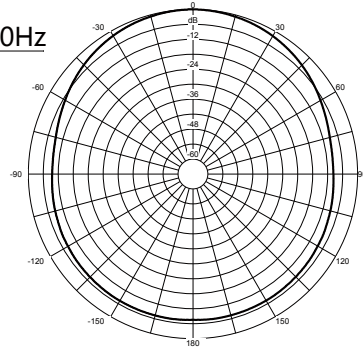

500Hz

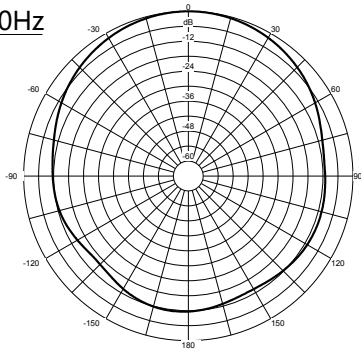

1000Hz

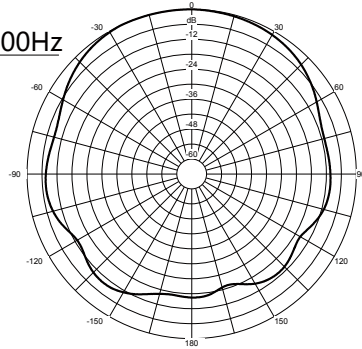

2000Hz

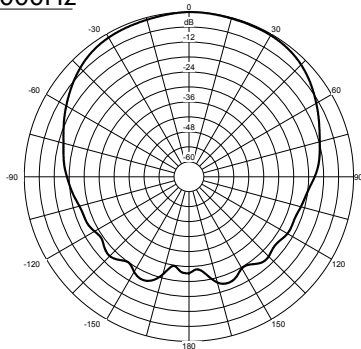

4000Hz

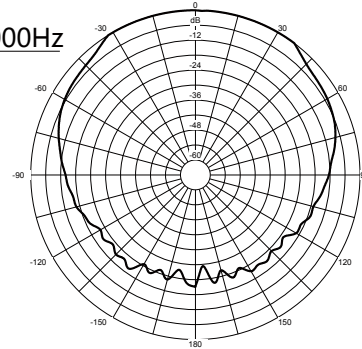

8000Hz

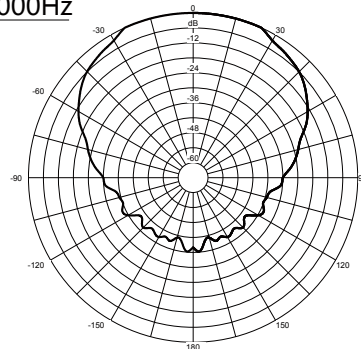

16000Hz

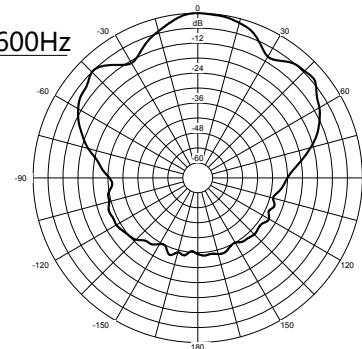

# FOCUS-15 VERTICAL POLAR GRAPHS

125Hz

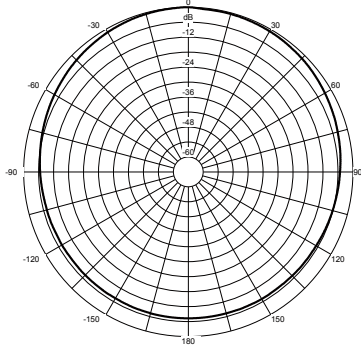

250Hz

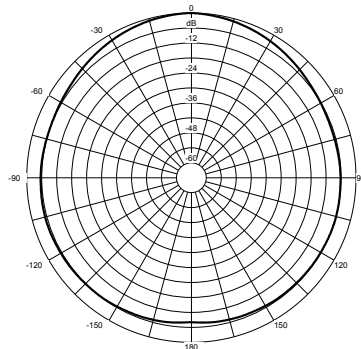

500Hz

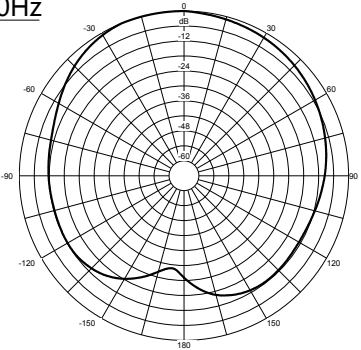

1000Hz

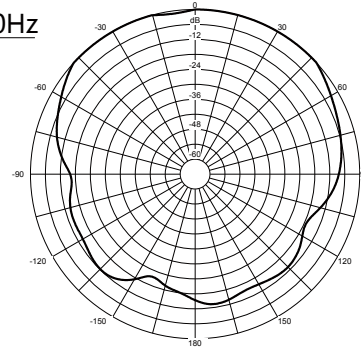

2000Hz

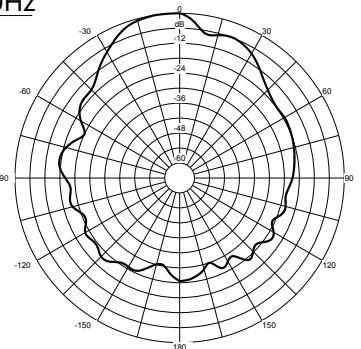

4000Hz

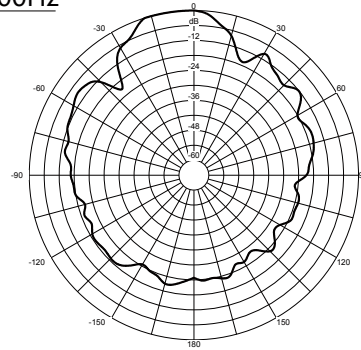

8000Hz

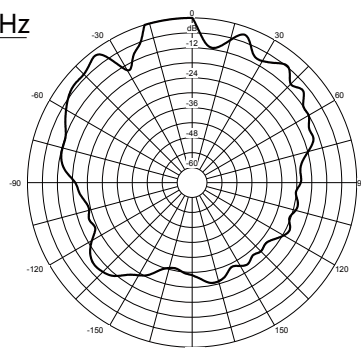

16000Hz

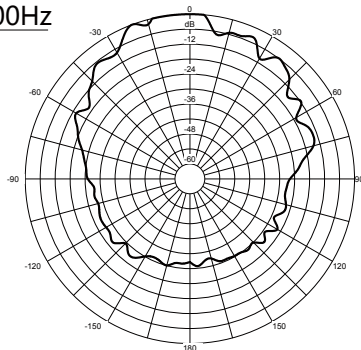

# SPECIFICATIONS

Model Name	FOCUS-12	FOCUS-15	FOCUS-18S	FOCUS-218S
System Type	12" 2 way	15" 2 way	18" Subwoofer	Dual 18" Subwoofer
Frequency Response (+/- 3dB)	60-20kHz	50-20kHz	35-800Hz	30-800Hz
Frequency Range (-10dB)	55-20kHz	45-20kHz	30-800Hz	25-800Hz
Continuous/Programme/Peak	500W/1000W/2000W	700W/1400W/2800W	1000W/2000W/4000W	Parallel: 2000W/4000W/8000W Discrete: 1000W/2000W/4000W
Nominal Impedance (ohms)	8Ω	8Ω	8Ω	Parallel: 4Ω Discrete: 2 x 8Ω
Sensitivity dB SPL @ 1W/1M Averaged Across Frequency Response	99.5dB	99.5dB	104dB	107dB
Max SPL dB SPL @ Peak Rated Power	133dB	135dB	140dB	146dB
Nominal Coverage @1kHz (H x V)	100° x 10°	100° x 10°	-	-
Crossover Frequency	1.6kHz	1.6kHz	-	-
Bi Amp Mode Switch	Yes	Yes	No	Yes
<b>LF Type</b>				
Size (mm / inches)	331mm/12"	390mm/15"	462mm/18"	462mm/18"
Power (Continuous RMS)	500W	700W	1000W	2 x 1000W
Sensitivity (Free Field 1W @ 1M)	98dB	99dB	99dB	99dB
Voice Coil (mm / inches)	76.2mm/3"	102mm/4"	114.3mm/4.5"	114.3mm/4.5"
Cone Material	Paper	Paper	Paper	Paper
Voice Coil Material	Copper	Copper	Copper	Copper
Voice Coil Former Material	Fibre Glass	Fibre Glass	Fibre Glass	Fibre Glass
Basket Material	Aluminium	Aluminium	Aluminium	Aluminium
Basket Type	Die-Cast	Die-Cast	Die-Cast	Die-Cast
Magnet Structure Mass	2.54kg/5.588lbs	3.64kg/8.0lbs	4.28kg/9.42lbs	4.28kg/9.42lbs
Magnet Structure Material	Ferrite	Ferrite	Ferrite	Ferrite
<b>HF Type</b>				
Power (Continuous RMS)	75W	75W	-	-
Sensitivity (Free Field 1W @ 1M)	106dB	106dB	-	-
Voice Coil (mm / inch)	81mm/3.2"	81mm/3.2"	-	-
Waveguide Type	square	square	-	-
Waveguide Exit (mm / inch)	35.5mm/1.4"	35.5mm/1.4"	-	-
Diaphragm Material	Titanium	Titanium	-	-
Voice Coil Former Material	Kapton	Kapton	-	-
Magnet Structure Mass	0.594kg/1.31lbs	0.594kg/1.31lbs	-	-
Magnet Structure Material	Neodymium	Neodymium	-	-
Protection	SK3	SK3	-	-
Enclosure Material and Thickness	15mm Plywood	15mm Plywood	18mm Plywood	18mm Plywood
Enclosure Finish	Black Rhino Paint	Black Rhino Paint	Black Rhino Paint	Black Rhino Paint
Grille Material & Finish	1.5mm Steel	1.5mm Steel	1.5mm Steel	1.5mm Steel
Colour Options	Balck	Balck	Balck	Balck
Rigging Points	M10X11 & 4 Fly Track	M10X11 & 4 Fly Track	-	-
Rigging Point Max Rated Weight	500kg	500kg	-	-
Pole Mount	Dual-angle (0° or -10°) 35mm pole socket	Dual-angle (0° or -10°) 35mm pole socket	M20 screw-on pole mount	M20 screw-on pole mount
Wheels	-	-	2	2
Handles	2 on sides	2 on sides	4 on sides	4 on sides
Input Connector Type	2 x Speakon	2 x Speakon	2 x Speakon	2 x Speakon
Net Weight (kg / Lbs)	26.3 / 57.9	34.1 / 75	52.4 / 115.3	86.5 / 190.3
Gross Weight (kg / Lbs)	28.2 / 62.04	36.5 / 80.3	61.3 / 134.9	98 / 215.6
Product Dimensions (H x W x D)mm	625 x 390/199.3 x 370.7	690 x 445/224.5 x 433	540 x 490 x 900	540 x 880 x 900
Carton Dimensions (H x W x D)mm	695 x 455/270 x 435	750 x 500/285 x 507	615 x 560 x 970	615 x 960 x 970

### **WHARFEDALE PRO LIMITED WARRANTY**

Wharfedale Pro products are warranted of manufacturing or material defects for a period of one year from the original date of purchase. In the event of malfunction, contact your authorized Wharfedale Pro dealer or distributor for information.

\*Be aware that warranty details may differ from country to country. Contact your dealers or distributor for information. These terms do not infringe your statutory rights.



Wharfedale Professional  
IAG House, 13/14 Glebe Road, Huntingdon, Cambridgeshire, PE29 7DL, UK  
[www.wharfedalepro.com](http://www.wharfedalepro.com)

Wharfedale Professional reserves the right to alter or improve specifications without notice.  
All rights reserved © 2013 Wharfedale Pro. Wharfedale Pro is a member of the IAG Group.