

Pack a **PUNCH**



IVA PS-15R2 Loudspeaker

RUGGED ROBUST ROADWORTHY



IVA

www.IVA.COM.MY

IVA PS-15R2 LOUDSPEAKER

RUGGED ROBUST ROADWORTHY

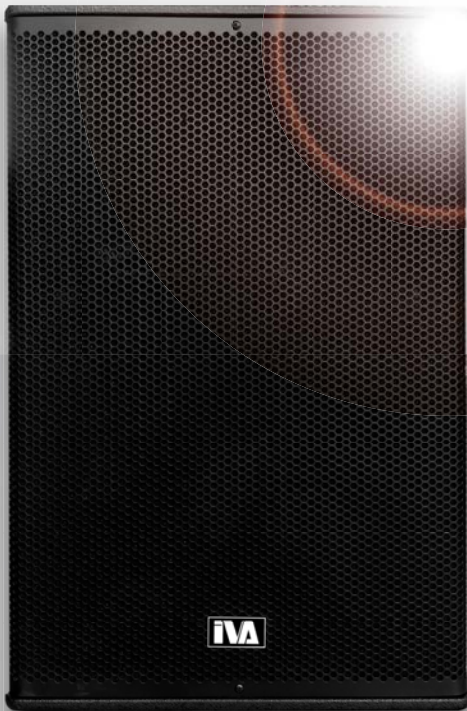

DESCRIPTION

What do you think is good value product? IVA PS-15R2 give the best value in your investment by giving you a very powerful audio and great sounding box. We have selected the best performance woofer and tweeter in its range for the loudspeaker. Coupled with our 13 years of experience in audio, we designed the crossover with the best grade of electronic components in its range. And it fits perfectly between the of the woofer and tweeter. The resultant of the ultra-detail crossover design is the ultra-linear crossing between the tweeter and woofer. For ordinary people, this linear crossing of the sound will be so sweet that it will be a listening sensation to the ears. The cabinet design itself was design from a user perspective. So much of the human touch was included in the design, making it one of the most portable friendly loudspeaker design. To amplify the performance, use IVA amplifier and IVA digital speaker management to elevate your system to next level.

PS-15R2

FEATURES

- Supreme Quality Woofer that you can hear and feel the bass
- Superior Tweeter for crystal clear audio from near to far field
- Ultra-linear crossover design
- Big handle for easy handling
- Side handle for easy floor deployment
- Rotatable horn for flexible vertical or horizontal mount



**Supreme Quality
Woofer**



Superior Tweeter



Big Handle



Side Handle

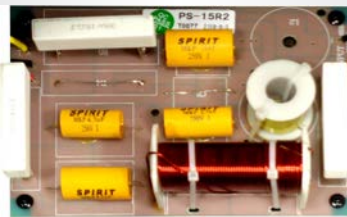

**Ultra-linear
Crossover Design**



Rotatable Horn

FREQUENCY GRAPH

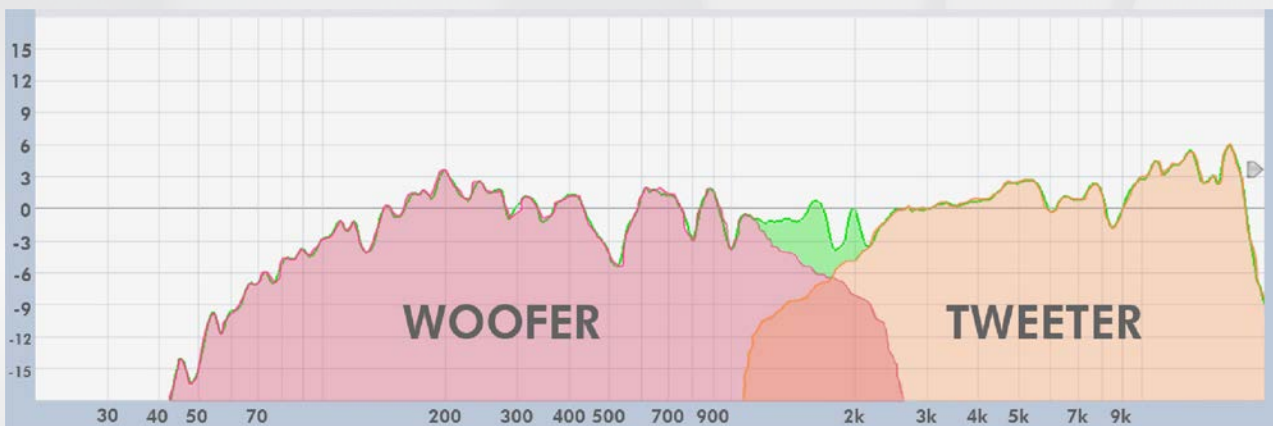

3 VIEWS

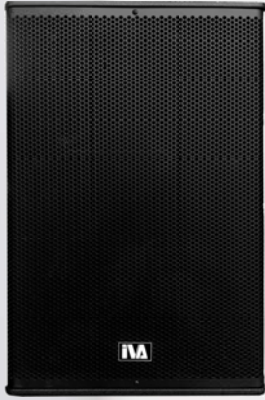

Front



Side



Rear

FRONT-OF HOUSE CONFIGURATION

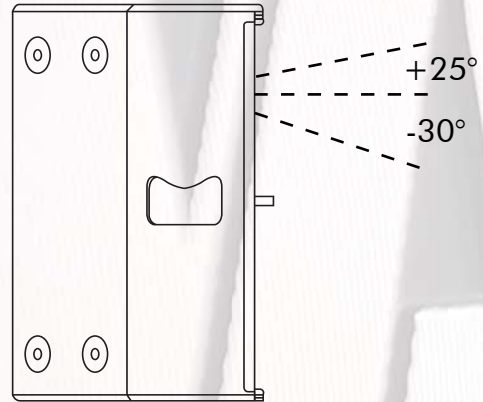
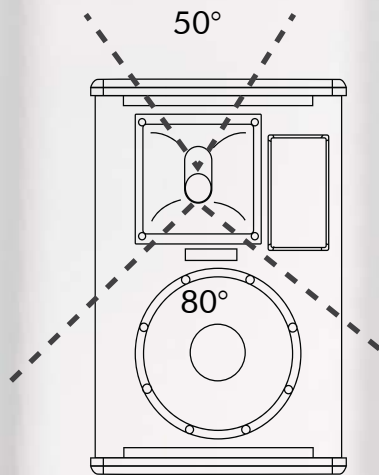

STAGE MONITOR CONFIGURATION

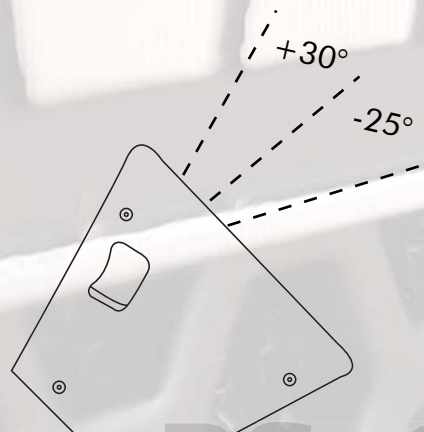
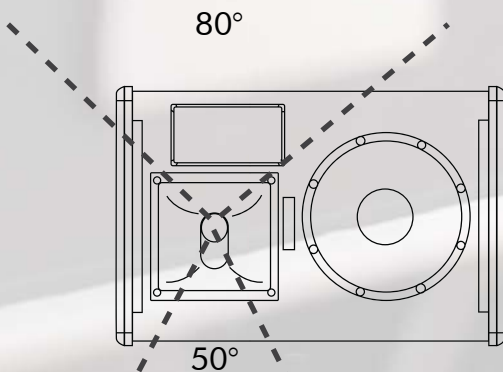

DIMENSION

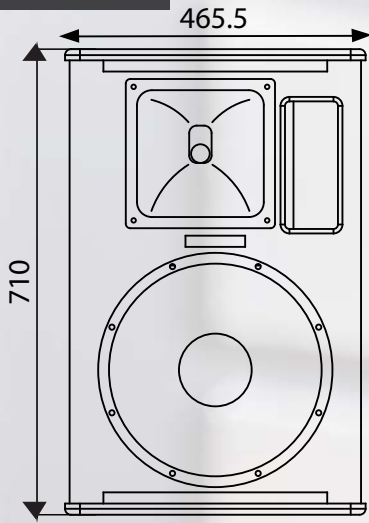

Front

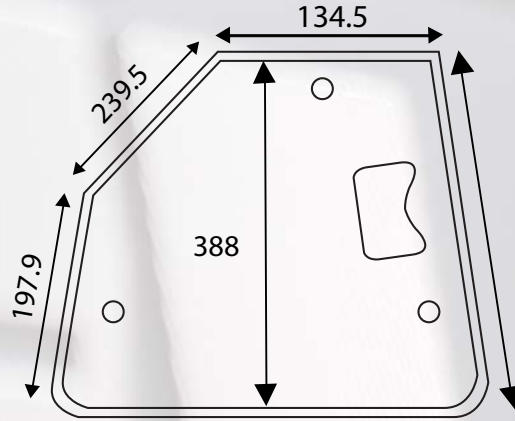

Top

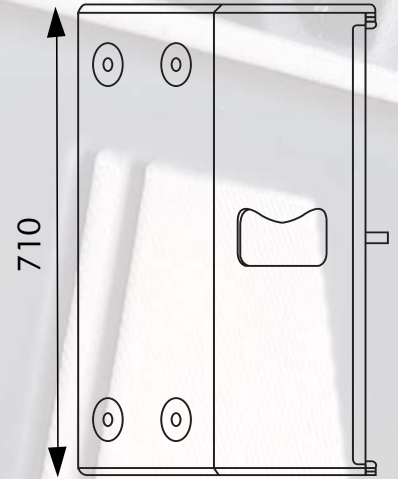

Side

HORN DISPERSION DESIGN

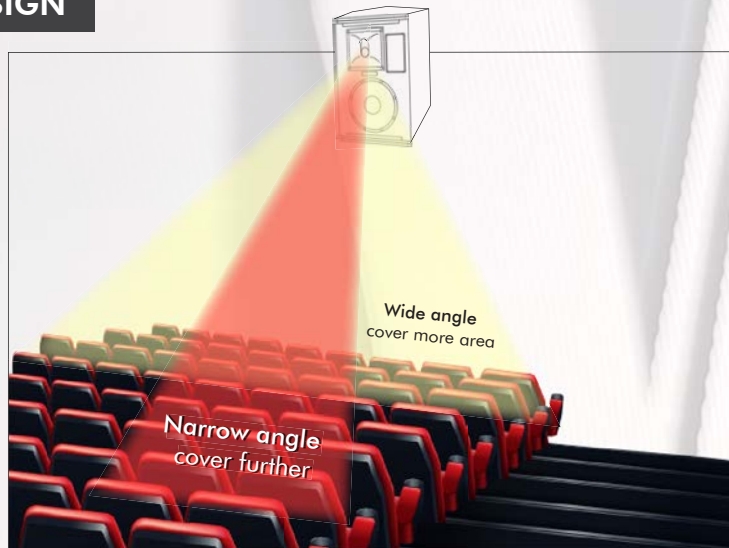

INSTALLATION METHOD

SPECIFICATIONS

Model	PS-15R2
System Type	2 Way 15" Fullrange
Woofer	15" Kapton 3" Voice Coil
Tweeter	1.75" Titanium Compression
Frequency Response	50Hz~20KHz
Dispersion	80° x 55° (H x V)
Handling Power	500W RMS
Sensitivity	98dB
Maximum SPL	132dB
Rotatable Horn	Yes
Suspension	5*M8
Type of Wood	High Density Fiberboard Wood
Dimensions (W x D x H)	465.5 x 388 x 716mm
Weight	26Kg
Packaging Dimensions (W x D x H)	450 x 530 x 760mm
Packaging Weight	29.5kg

BEST COMPATIBLE SYSTEM

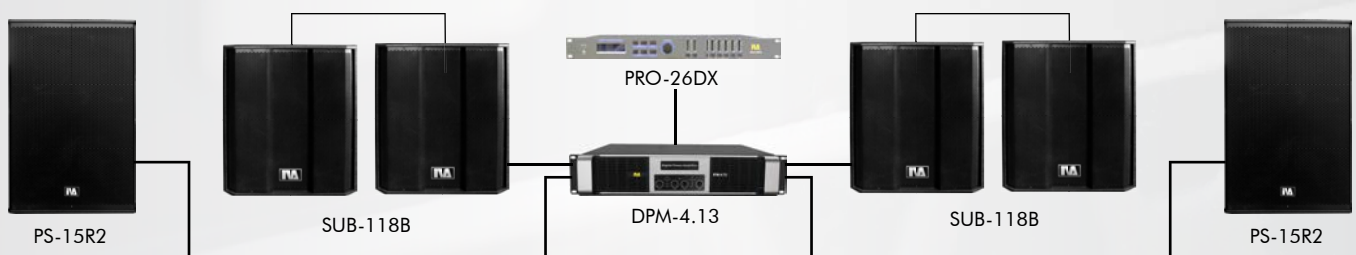

PS-15R2