



User's Manual

Installation HQ Series

*HQ-112.43 / HQ-112.64 / HQ-112.95
HQ-218 / HQ-212.64 / HQ-212.95*



Antes de utilizar el equipo, lea la sección "Precauciones de seguridad" de este manual. Conserve este manual para futuras consultas.

Before operating the device, please read the "Safety precautions" section of this manual. Retain this manual for future reference.

CONTENTS

SAFETY PRECAUTIONS	3
WARRANTY	4
DECLARATION OF CONFORMITY	5
INTRODUCTION	6 - 8
CONFIGURATIONS	9 - 11
4x HQ-112.xx (horizontal array)	
4x HQ-112.95 + 2x HQ-218 (horizontal array)	
6x HQ-112.43 + 2x HQ-218 (vertical array)	
16x HQ-212.XX + 1x DX-100I	
16x HQ-212.XX bi-amp + 1x DX-100I + 1x DX-80	
SPECIFICATIONS	12
LINE DRAWINGS	13 - 14
INSTALLATION	15 - 20
ACCESSORIES	21 - 24
ANNEX: Table for cable selection	25

Cajas acústicas pasivas / Passive loudspeaker enclosures

Conserve y lea todas estas instrucciones.

Siga todas las advertencias.

El signo de exclamación dentro de un triángulo indica la existencia de componentes internos cuyo reemplazo puede afectar a la seguridad.



Keep these instructions.

Heed all warnings. Follow all instructions.

The exclamation point inside an equilateral triangle indicates the existence of internal components whose substitution may affect safety.

El doble cuadrado indica equipo de Clase II.



The double square indicates Class II device.

Las especificaciones se encuentran en la etiqueta de la parte posterior del producto.

The specifications can be found on the rear label of the product.

El colgado del equipo sólo debe realizarse utilizando los herrajes de colgado recomendados y por personal cualificado.

The appliance should be flown only from the rigging points and by qualified personnel.

No exponga este equipo a la lluvia o humedad sin el protector de lluvia recomendado. No use este aparato cerca del agua (piscinas y fuentes, por ejemplo). No exponga el equipo a salpicaduras sin el protector de lluvia recomendado, ni coloque sobre él objetos que contengan líquidos, tales como vasos y botellas.

Do not expose this device to rain or moisture without the rain protector supplied. Do not use this apparatus near water (for example, swimming pools and fountains). Do not place any objects containing liquids, such as bottles or glasses, on the top of the unit. Do not splash liquids on the unit without the rain protector supplied.

Este símbolo indica que el presente producto no puede ser tratado como residuo doméstico normal, sino que debe entregarse en el correspondiente punto de recogida de equipos eléctricos y electrónicos.



This symbol on the product indicates that this product should not be treated as household waste. Instead it shall be handed over to the applicable collection point for the recycling of electrical and electronic equipment.

Equipo diseñado para funcionar entre 15°C y 45°C con una humedad relativa máxima del 95%.

Working temperature ranges from 15°C to 45°C with a relative humidity of 95%.

El cableado exterior conectado al equipo requiere de su instalación por una persona instruida.

The outer wiring connected to the device requires installation by an instructed person.

El equipo cuenta con un terminal de entrada tipo regleta de tornillo para facilitar la conexión.

Device with terminal strip input to provide an easy connection.

No emplace altavoces en proximidad a equipos sensibles a campos magnéticos, tales como monitores de televisión o material magnético de almacenamiento de datos.



Do not place loudspeakers in proximity to devices sensitive to magnetic fields such as television monitors or data storage magnetic material.

No existen partes ajustables por el usuario en el interior de este equipo. Cualquier operación de mantenimiento o reparación debe ser realizada por personal cualificado. Es necesario el servicio técnico cuando el aparato se haya dañado de alguna forma, tal como que haya caído líquido o algún objeto en el interior del aparato, haya sido expuesto a lluvia o humedad, no funcione correctamente o haya recibido un golpe.

No user serviceable parts inside. Refer all servicing to qualified service personnel. Servicing is required when the apparatus has been damaged in any way, such as power-supply cord or plug is damaged, liquid has been spilled or objects have fallen into the apparatus, the apparatus has been exposed to rain or moisture, does not operate normally or has been dropped.

Limpie con un paño seco. No use limpiadores con disolventes.

Clean only with a dry cloth. Do not use any solvent based cleaners.

GARANTÍA

Todos nuestros productos están garantizados por un periodo de 24 meses desde la fecha de compra.

Las garantías sólo serán válidas si son por un defecto de fabricación y en ningún caso por un uso incorrecto del producto.

Las reparaciones en garantía pueden ser realizadas, exclusivamente, por el fabricante o el servicio de asistencia técnica autorizado.

Otros cargos como portes y seguros, son a cargo del comprador en todos los casos.

Para solicitar reparación en garantía es imprescindible que el producto no haya sido previamente manipulado e incluir una fotocopia de la factura de compra.

WARRANTY

All our products are warranted against any manufacturing defect for a period of 2 years from date of purchase.

The warranty excludes damage from incorrect use of the product.

All warranty repairs must be exclusively undertaken by the factory or any of its authorised service centers.

To claim a warranty repair, do not open or intend to repair the product.

Return the damaged unit, at shippers risk and freight prepaid, to the nearest service center with a copy of the purchase invoice.



DECLARACIÓN DE CONFORMIDAD DECLARATION OF CONFORMITY

DAS Audio Group, S.L.

C/ Islas Baleares, 24 - 46988 - Pol. Fuente del Jarro - Valencia. España
(Spain).

Declara que la *serie HQ*:

Declares that *HQ series*:

Cumple con los objetivos esenciales de las Directivas:

Abide by essential objectives relating Directives:

- De Baja Tensión / Low Voltage 2014/35/UE
- RoHS 2011/65/UE
- RAEE (WEEE) 2012/19/UE

Y es conforme a las siguientes Normas Armonizadas Europeas:

In accordance with Harmonized European Norms:

- EN 60065:2014.- Audio, video and similar electronic apparatus. Safety requirements.
- EN 50581:2012.- Technical documentation for the assessment of electrical and electronic products with respect to the restriction of hazardous substances.

INTRODUCTION

The **DAS HQseries** is designed for medium to large scale installations such as arenas, stadiums, auditoriums and theaters. The HQ models offer tightly controlled coverage patterns and high output capabilities being usable individually, or in multiple unit arrays. The models are offered in FX paint finish. This finish is adequate for applications where cabinets are covered or protected, and where cabinets are unprotected and directly exposed to the environment. All versions are rated IP54.

Features

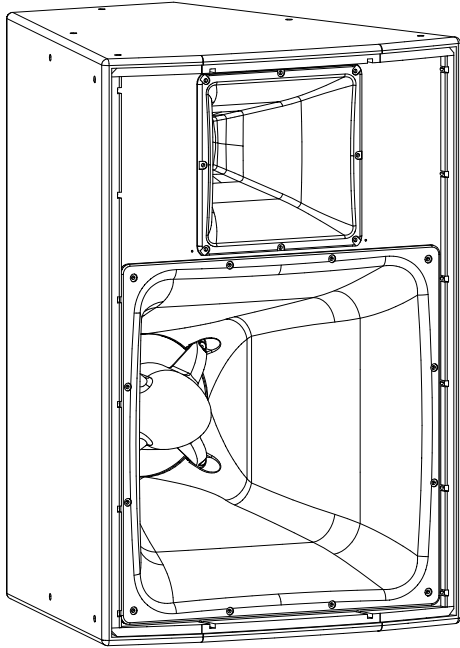

HQ-112.43

- Two-way system with 2 selectable operating modes: passive system or Bi-amplified system.
- 12" bass loudspeaker, **12HQ**, 3" VCD.
- Compression driver with titanium diaphragm, **M-78N**, 3" VCD.
- Rotatable 40° x 30° horn design
- Trapezoid geometry enclosure
- Finish: FX covered and direct exposure
- 20 built-in rigging points.

The **HQ-112.43** is a two way configurable system, bi-amplified or passive full-range, using a subwoofer of 12", compression driver, **M78N**, with exit of 1.5" and titanium diaphragm. To improve the acoustic response, it is equipped with two horns (one for medium frequencies and other for high frequencies), and both are rotatable.

The FX finish protects the cabinets outdoors thanks to a fiberglass exterior and ISO-flex interior protection augmenting their weather resistance when used in direct exposure situations.

In the front, there is a perforated steel grill which protects the components.

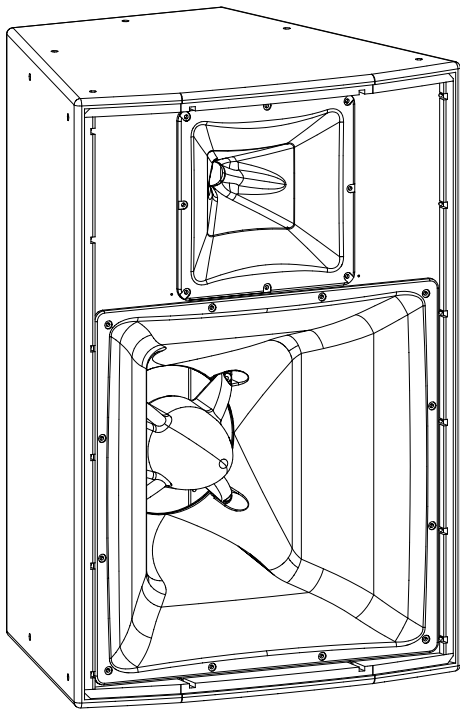

HQ-112.64

- Two-way system with 2 selectable operating modes: passive system or Bi-amplified system.
- 12" bass loudspeaker, **12HQ**, 3" VCD.
- Compression driver with titanium diaphragm, **M-78N**, 3" VCD.
- Rotatable 60° x 40° horn design
- Trapezoid geometry enclosure
- Finish: FX covered and direct exposure
- 20 built-in rigging points.

The **HQ-112.64** is a two way configurable system, bi-amplified or passive full-range, using a subwoofer of 12", compression driver, **M78N**, with exit of 1.5" and titanium diaphragm. To improve the acoustic response, it is equipped with two horns (one for medium frequencies and other for high frequencies), and both are rotatable.

The FX finish protects the cabinets outdoors thanks to a fiberglass exterior and ISO-flex interior protection augmenting their weather resistance when used in direct exposure situations.

In the front, there is a perforated steel grill which protects the components.

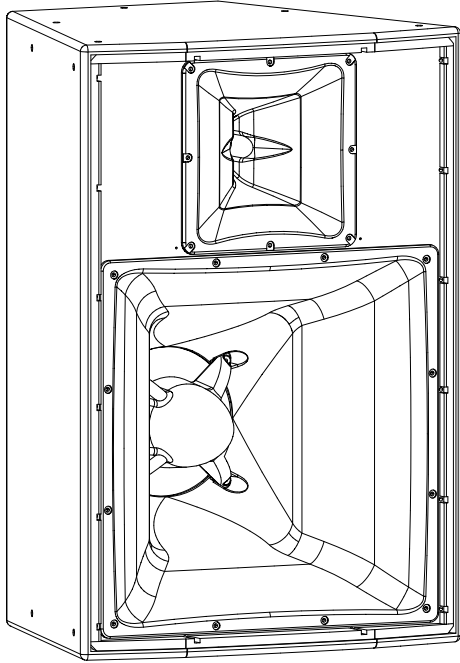

HQ-112.95

- Two-way system with 2 selectable operating modes: passive system or Bi-amplified system.
- 12" bass loudspeaker, **12HQ**, 3" VCD.
- Compression driver with titanium diaphragm, **M-78N**, 3" VCD.
- Rotatable 90° x 50° horn design
- Trapezoid geometry enclosure
- Finish: FX covered and direct exposure
- 20 built-in rigging points.

The **HQ-112.95** is a two way configurable system, bi-amplified or passive full-range, using a subwoofer of 12", compression driver, **M78N**, with exit of 1.5" and titanium diaphragm. To improve the acoustic response, it is equipped with two horns (one for medium frequencies and other for high frequencies), and both are rotatable.

The FX finish protects the cabinets outdoors thanks to a fiberglass exterior and ISO-flex interior protection augmenting their weather resistance when used in direct exposure situations.

In the front, there is a perforated steel grill which protects the components.

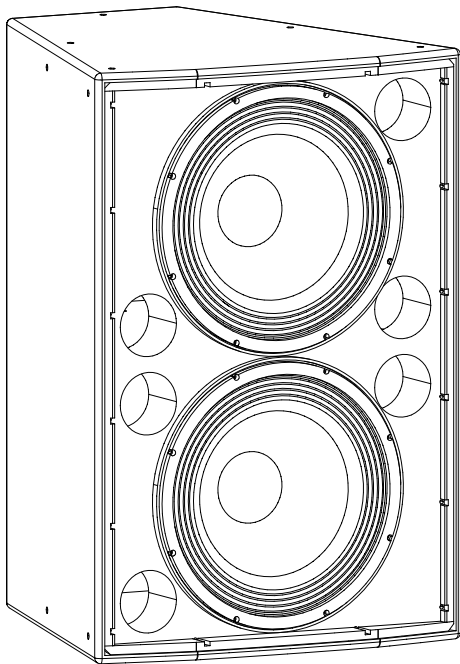

HQ-218

- Bass-reflex subwoofer system.
- 18" low frequency transducer, **18LX**, 4" VCD.
- Precise and powerful bass reproduction.
- Trapezoid geometry enclosure
- Finish: FX covered and direct exposure
- 20 built-in rigging points.

The **HQ-218** is a subwoofer system that incorporates a 18" low frequency transducer with a 4" voice coil mounted as a direct radiator into a bass-reflex cabinet.

The FX finish protects the cabinets outdoors thanks to a fiberglass exterior and ISO-flex interior protection augmenting their weather resistance when used in direct exposure situations.

The loudspeaker is protected by a perforated steel grille, sealed against corrosion using a powder coat finish.

HQ-212.64

- Two-way long-throw system
- Horn loaded 2 X 12" low frequency loudspeaker, **12LQN4C**, 3" VCD
- **M-78N** neodymium compression driver, 3" VCD
- Selectable passive/biamped operating modes
- Tight 60° x 40° coverage angles
- Rotatable horns
- Stainless steel rigging kit

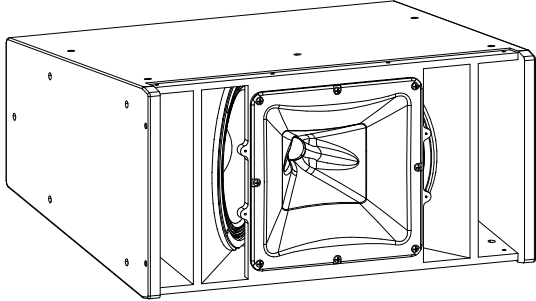

The DAS **HQ-212.64** is designed for medium to large scale installations such as arenas, auditoriums, stadiums and theaters. The HQ models offer tightly controlled coverage patterns and high output capabilities being usable individually, or in multiple unit arrays. The series enclosures incorporate cutting-edge interior and exterior coatings for weather resistance and extended durability in extreme environments.

The FX finish protects the cabinets outdoors thanks to a fiberglass exterior and ISO-flex interior protection augmenting their weather resistance when used in direct exposure situations.

In the front, there is a perforated steel grill which protects the components.

HQ-212.95

- Two-way long-throw system
- Horn loaded 2 X 12" low frequency loudspeaker, **12LQN4C**, 3" VCD
- **M-78N** neodymium compression driver, 3" VCD
- Selectable passive/biamped operating modes
- Tight 90° x 50° coverage angles
- Rotatable horns
- Stainless steel rigging kit

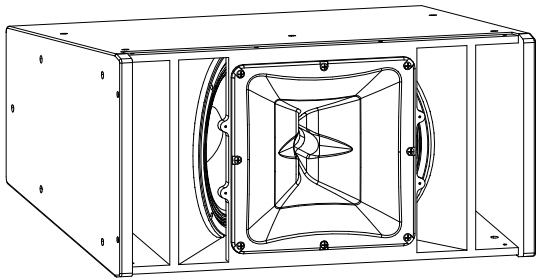

The DAS **HQ-212.95** is designed for medium to large scale installations such as arenas, auditoriums, stadiums and theaters. The HQ models offer tightly controlled coverage patterns and high output capabilities being usable individually, or in multiple unit arrays. The series enclosures incorporate cutting-edge interior and exterior coatings for weather resistance and extended durability in extreme environments.

The FX finish protects the cabinets outdoors thanks to a fiberglass exterior and ISO-flex interior protection augmenting their weather resistance when used in direct exposure situations.

In the front, there is a perforated steel grill which protects the components.

CONFIGURATIONS

Next, you will see three examples. You will find more configurations on our website.

4x HQ-112.xx (horizontal array)

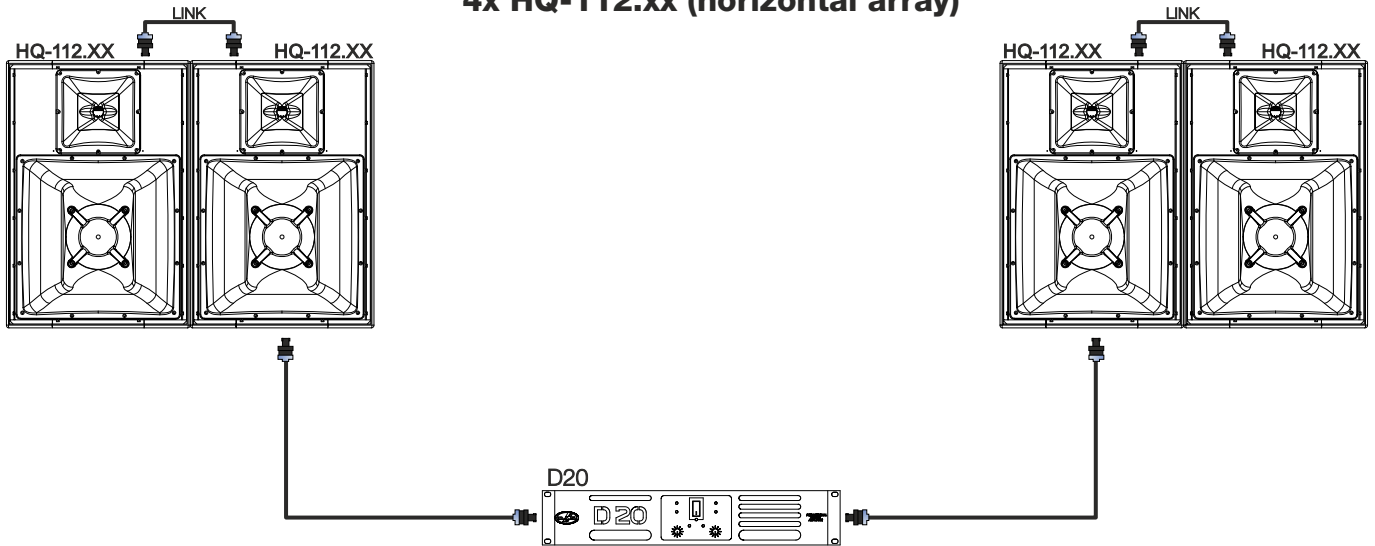

4x HQ-112.95 + 2x HQ-218 (horizontal array)

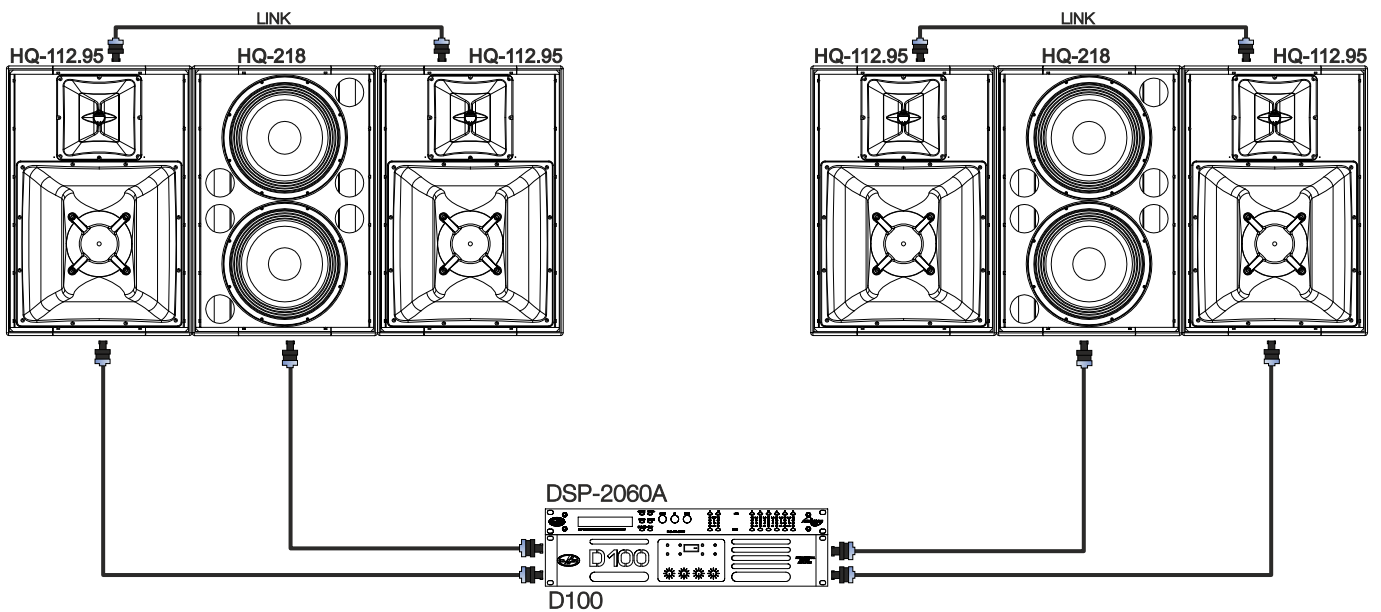

PRC (Power Reduction Control) for D-100:

PRC = 0 dB for HQ-218

PRC = -4 dB for HQ-112.xx

6x HQ-112.43 + 2x HQ-218 (vertical array)

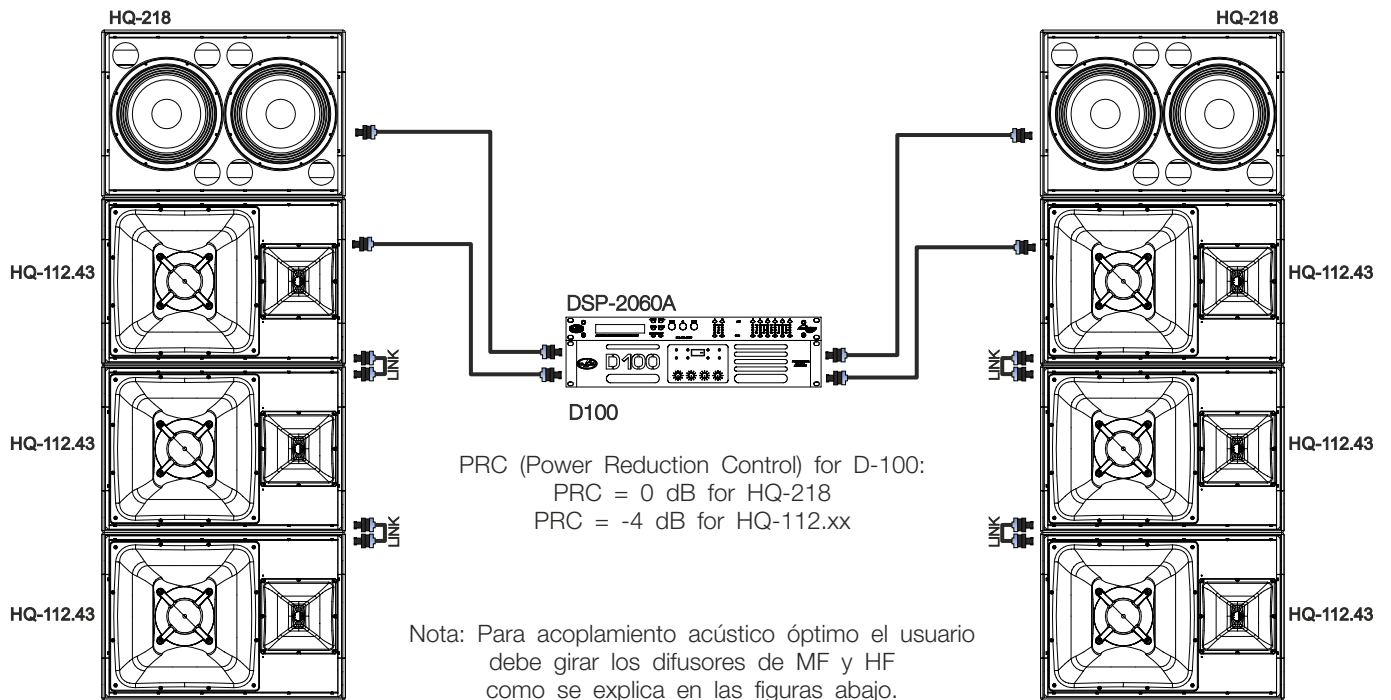

Note: For optimal acoustic coupling the user must rotate MF and HF horns as explained in the images below.

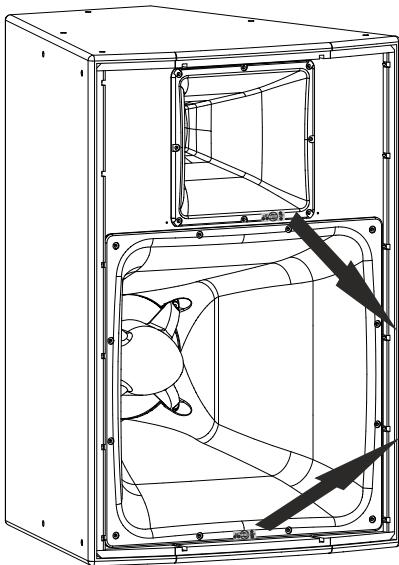

Factory horns settings for the HQ-112.43

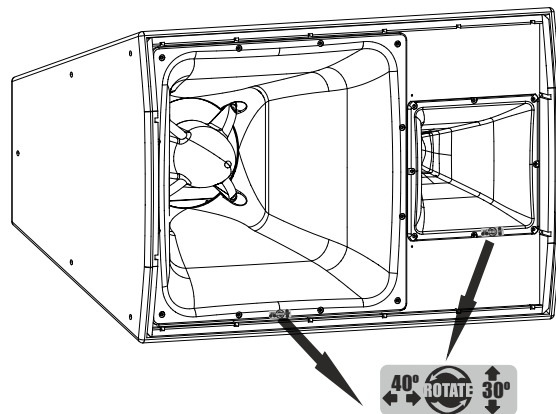

Horns settings for vertical arrays with HQ-112.43.

16x HQ-212.XX + 1x DX-100I

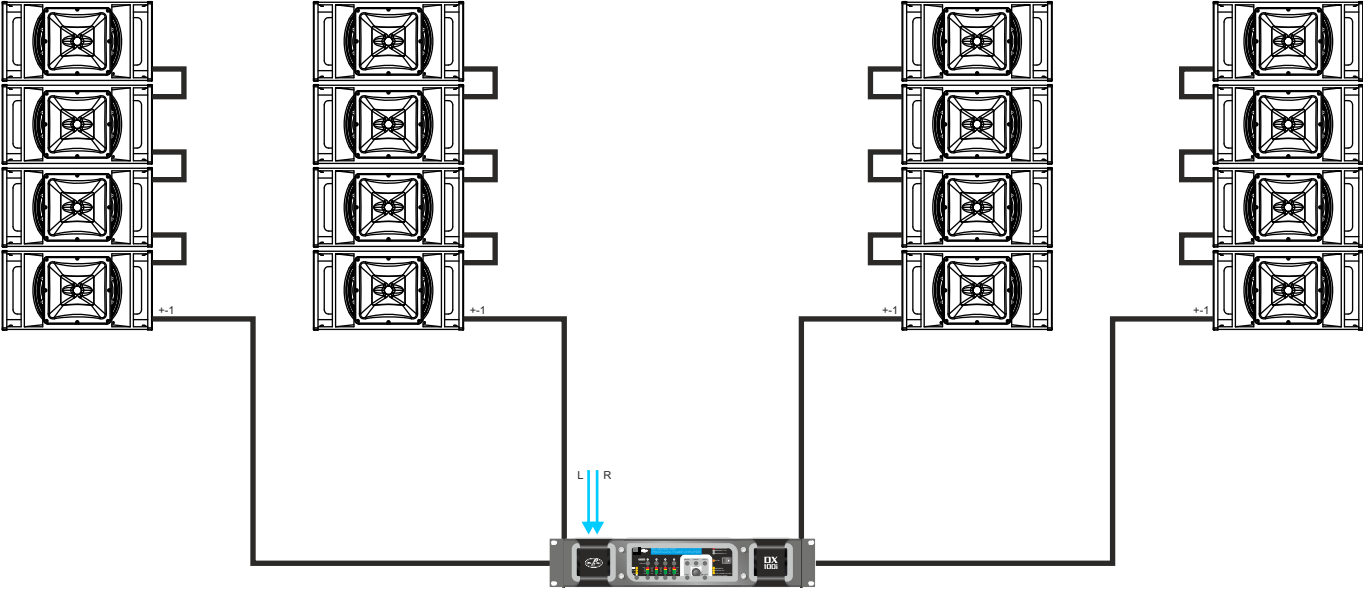

16x HQ-212.XX bi-amp + 1x DX-100I + 1x DX-80

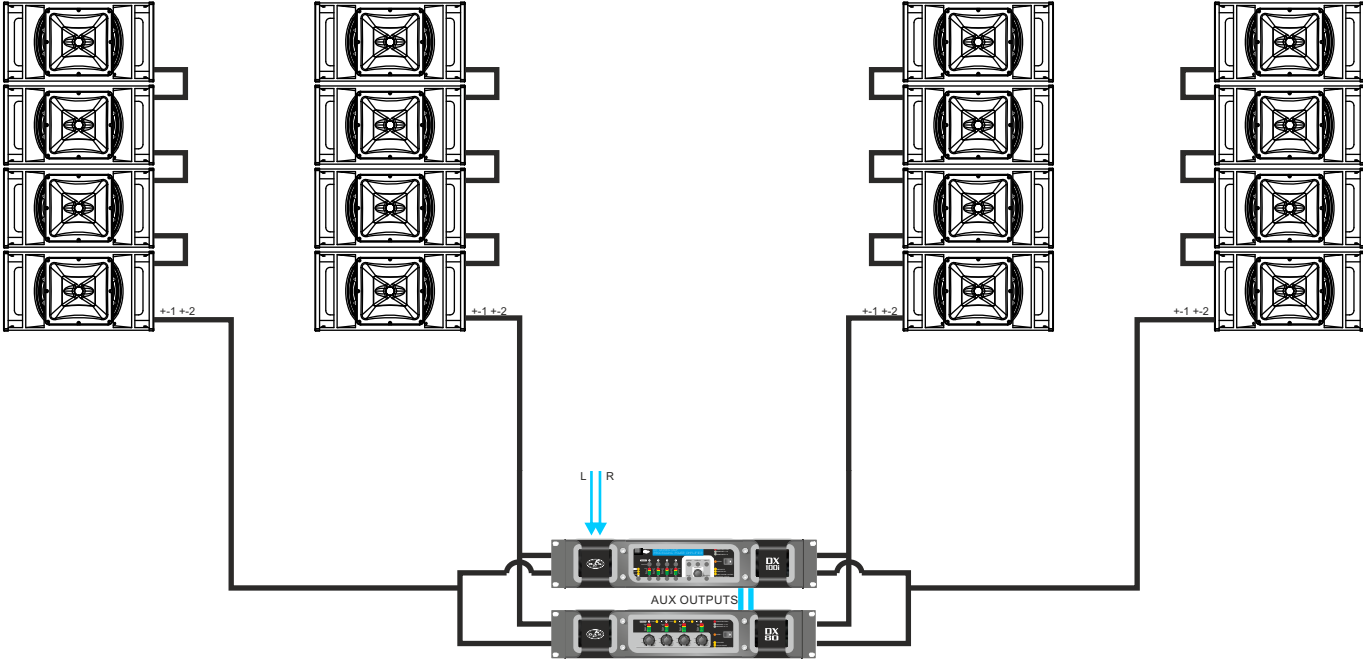

SPECIFICATIONS

<i>Model</i>	HQ-112.43	HQ-112.64	HQ-112.95
RMS (Average) Power Handling¹	400W	400 W	400 W
Peak Power Handling	1600W	1600W	1600W
Frequency Range (-10 dB)²	80 Hz-18 kHz	80 Hz-18 kHz	80 Hz-18 kHz
Nominal Impedance	8 ohms	8 ohms	8 ohms
Crossover Modes	Passive / Bi-amp	Passive / Bi-amp	Passive / Bi-amp
On-axis Sensitivity 1 W/ 1 m	111 dB SPL	110 dB SPL	109 dB SPL
Rated Maximum Peak SPL at 1 m³	142 dB	141 dB	140 dB
HF Horn Coverage Angles (-6dB)	40° x 30° Rotatable	60° x 40° Rotatable	90° x 50° Rotatable
Enclosure Material	Birch Plywood	Birch Plywood	Birch Plywood
Color / Finish	Black or White (W) / FX: Fiberglass	Black or White (W) / FX: Fiberglass	Black or White (W) / FX: Fiberglass
Rigging points	20 x M10 threaded hardware	20 x M10 threaded hardware	20 x M10 threaded hardware
Transducers/Replacement Parts	LF: 1 x 12HQ/ GM 12HQ HF: M-78N / GM-M75	LF: 1 x 12HQ/ GM 12HQ HF: M-78N / GM-M75	LF: 1 x 12HQ/ GM 12HQ HF: M-78N / GM-M75
Connectors	Covered Barrier Strip & 2x NL4 speakON	Covered Barrier Strip & 2x NL4 speakON	Covered Barrier Strip & 2x NL4 speakON
Dimensions (H x W x D)	100 x 69 x 71.5 cm 39.4 x 27.2 x 28.2 in	100 x 69 x 60.5 cm 39.4 x 27.2 x 23.8 in	100 x 69 x 60.5 cm 39.4 x 27.2 x 23.8 in
Weight	79 kg 174 lb	70 kg 154 lb	70 kg 154 lb
Accessories	Stainless Steel kit for M10 rigging points ANL-2	Stainless Steel kit for M10 rigging points ANL-2	Stainless Steel kit for M10 rigging points ANL-2

<i>Model</i>	HQ-212.64	HQ-212.95	HQ-218
RMS (Average) Power Handling¹	800W	800 W	2000 W
Peak Power Handling	3200W	3200W	8000 W
Frequency Range (-10 dB)²	63 Hz-18 kHz	63 Hz-18 kHz	28 Hz – 125Hz
Nominal Impedance	8 ohms	8 ohms	4 ohms
Crossover Modes	Passive / Bi-amp	Passive / Bi-amp	Passive
On-axis Sensitivity 1 W/ 1 m	106dB SPL	105 dB SPL	101 dB SPL
Rated Maximum Peak SPL at 1 m³	141 dB	140 dB	140 dB
HF Horn Coverage Angles (-6dB)	60° x 40° Rotatable	90° x 50° Rotatable	----
Enclosure Material	Birch Plywood	Birch Plywood	Birch Plywood
Color / Finish	Black or White (W) / FX: Fiberglass	Black or White (W) / FX: Fiberglass	Black or White (W) / FX: Fiberglass
Rigging points	20 x M10 threaded hardware	20 x M10 threaded hardware	20 x M10 threaded hardware
Transducers/Replacement Parts	LF: 2 x 12LQN4C/ GM-12LQN4C HF: M-78N / GM-M75	LF: 2 x 12LQN4C/ GM-12LQN4C HF: M-78N / GM-M75	LF: 2 x 18LX/ GM 18LX
Connectors	Covered Barrier Strip	Covered Barrier Strip	Covered Barrier Strip & 2x NL4 speakON
Dimensions (H x W x D)	368 x 695 x 652 mm 14.5 x 27.4 x 25.7 in	368 x 695 x 652 mm 14.5 x 27.4 x 25.7 in	100 x 69 x 71.5 cm 39.4 x 27.2 x 28.2 in
Weight	39 kg 85.8 lb	39 kg 85.8 lb	75 kg 165 lb
Accessories	Stainless Steel kit for M10 rigging points ANL-2	Stainless Steel kit for M10 rigging points ANL-2	Stainless Steel kit for M10 rigging points ANL-2

- Notes: 1. Based on a 2 hour test continuously applying 6 dB crest factor pink noise.
2. In Bi-amp mode, with recommended active settings.
3. Maximum calculated Peak SPL based on sensitivity and RMS power handling.

DAS Audio Group S.L. continuously strives to enhance its products through investigation and development. All specifications are subject to change without prior notice.

LINE DRAWINGS

ALL DIMENSIONS IN MILLIMETERS

HQ-112.43

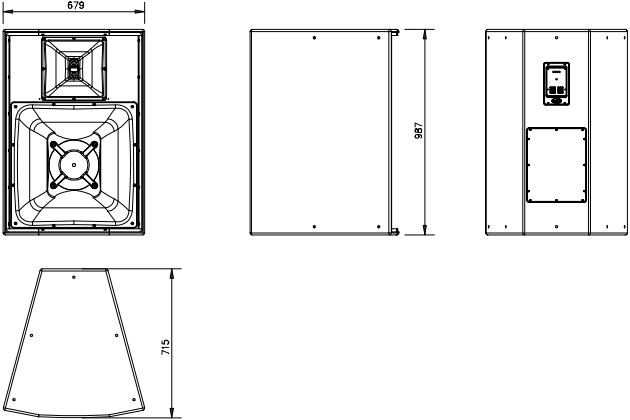

HQ-112.64

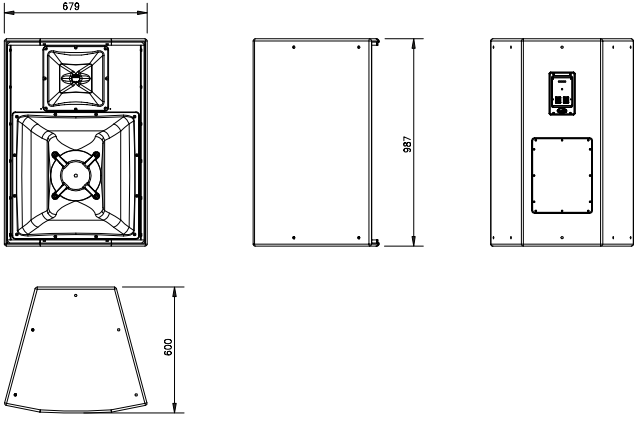

HQ-112.95

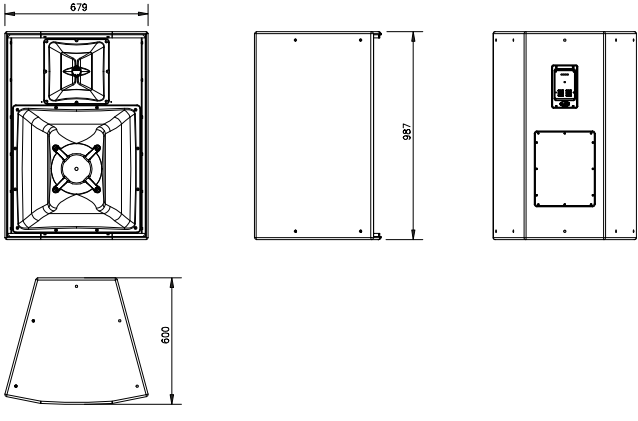

LINE DRAWINGS

ALL DIMENSIONS IN MILLIMETERS

HQ-212.64

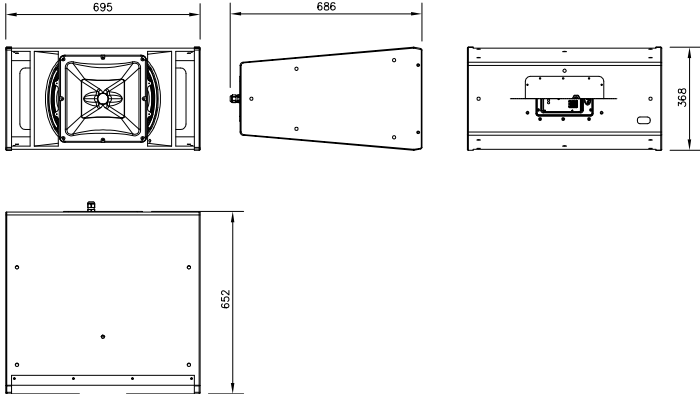

HQ-212.95

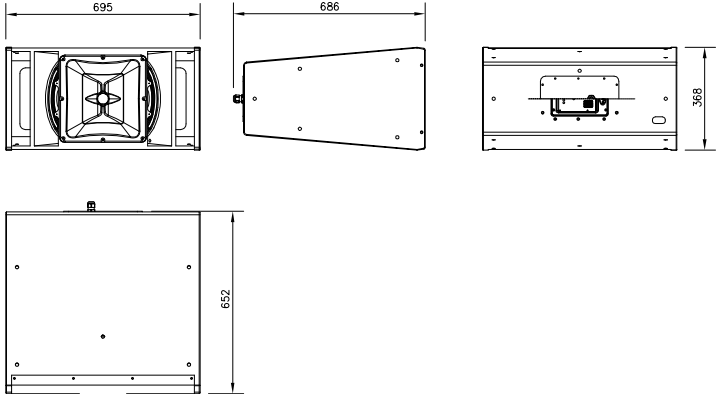

HQ-218

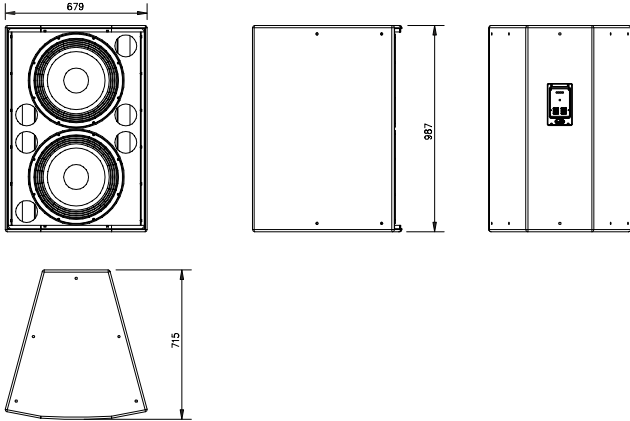

INSTALLATION

Connectors

The **DAS HQ series** is designed to facilitate the connection for installations, so it has been provided with two types of connectors: the NL4 type, standard for professional audio equipment (except *HQ-212.xx*), and screw terminals, easier to use in most types of installations. These terminals are connected in parallel, so that we can carry the amplified audio signal up to a device and we can forward it to the next box, very easily. The polarity of the connectors and other important information for proper connection is indicated on the labels.

**Switch to operating mode:
BI-AMPLIFIED - PASSIVE**

Rotatable horns

The *HQ-112.xx* and *HQ-212.xx* models of the **DAS HQ series** have been provided with rotatable horns to optimize the acoustic response of the unit group of installed systems. This will be necessary when we install the equipment horizontally, as stated in the following figures:

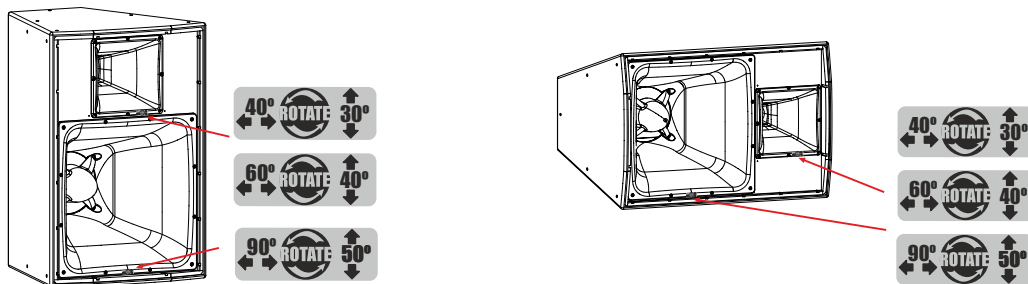

Factory horns settings for the HQ-112.xx

Horns settings for vertical arrays with HQ-112.xx

The system includes 5m of connection wire ready to use in the application. If more than 5m of connection wire is required, a longer cable can be used. If so proceed as follows:

- 1.- Prepare the rear part of the enclosure for cable connection, removing the existing cable.
- 2.- Screw the cables to the barrier strip following the label indications and the color code (attached figures).
- 3.- Fix the cover of the rear part of the enclosure with six screws. Don't remove after installation.

Color code for the models:

HQ-112.43

HQ-112.64

HQ-112.95

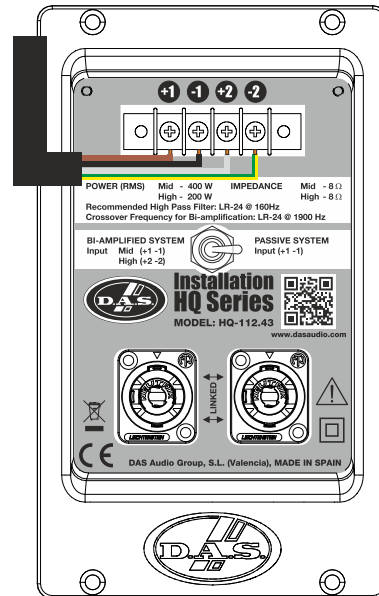

Color code for the model:

HQ-218

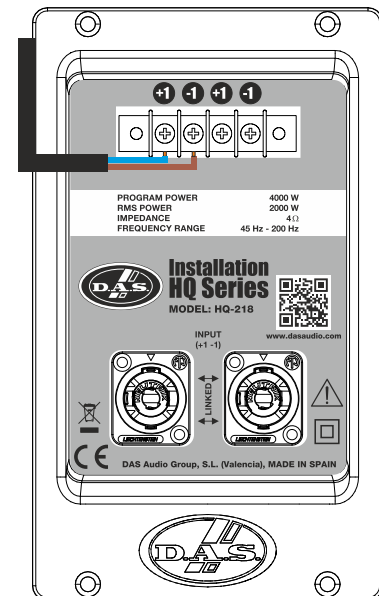
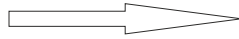

Color code for the models:

HQ-212.64

HQ-212.95

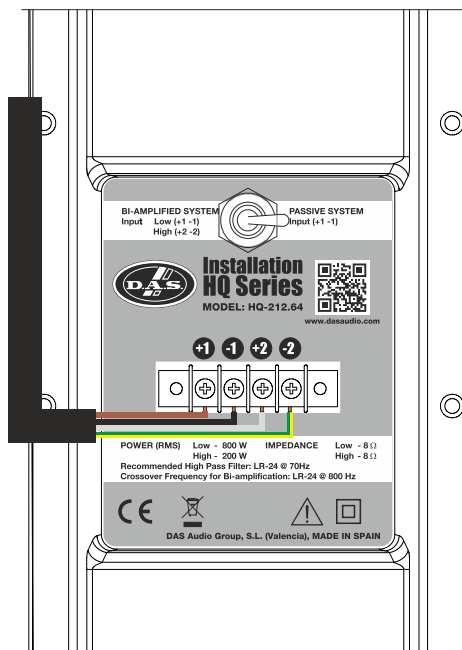

Example: HQ-212.95

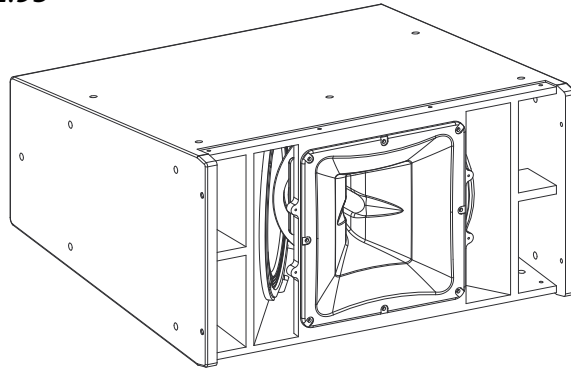

90° HORIZONTAL

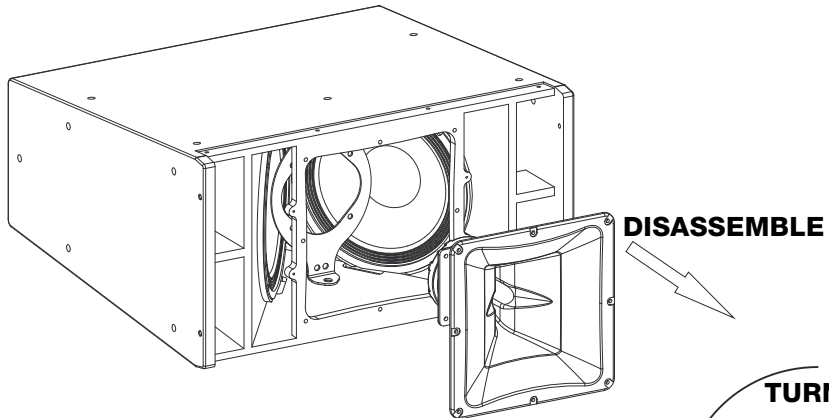

90° HORIZONTAL

TURN 90°

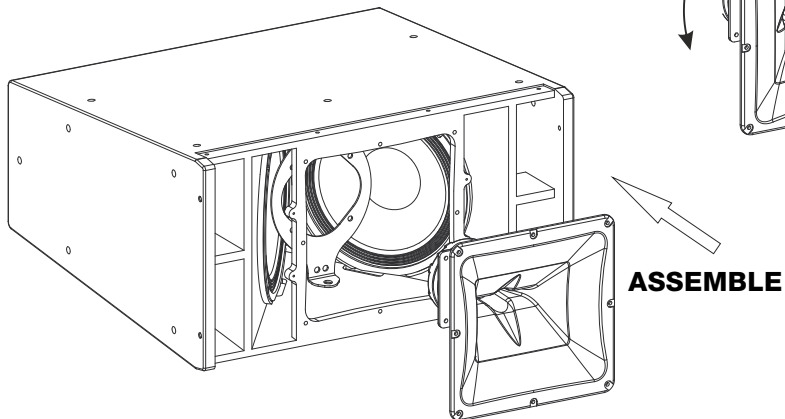
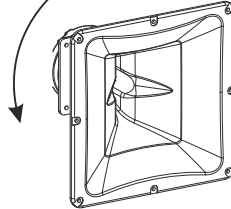

ASSEMBLE

After turn: 90° VERTICAL

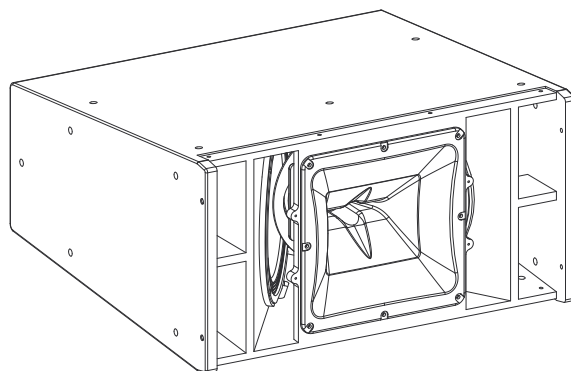

90° VERTICAL

Coverages

The **DAS HQ series** is designed with trapezoid enclosures to very easily achieve the desired coverages in fixed installations. Here are some basic examples.

Vertical Array 70° coverage

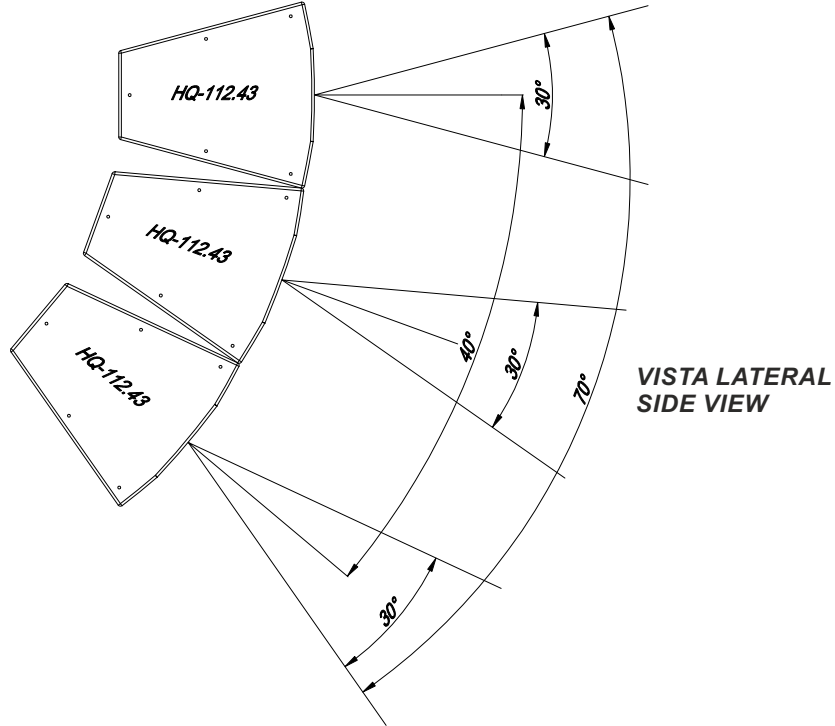

Vertical Array 110° coverage

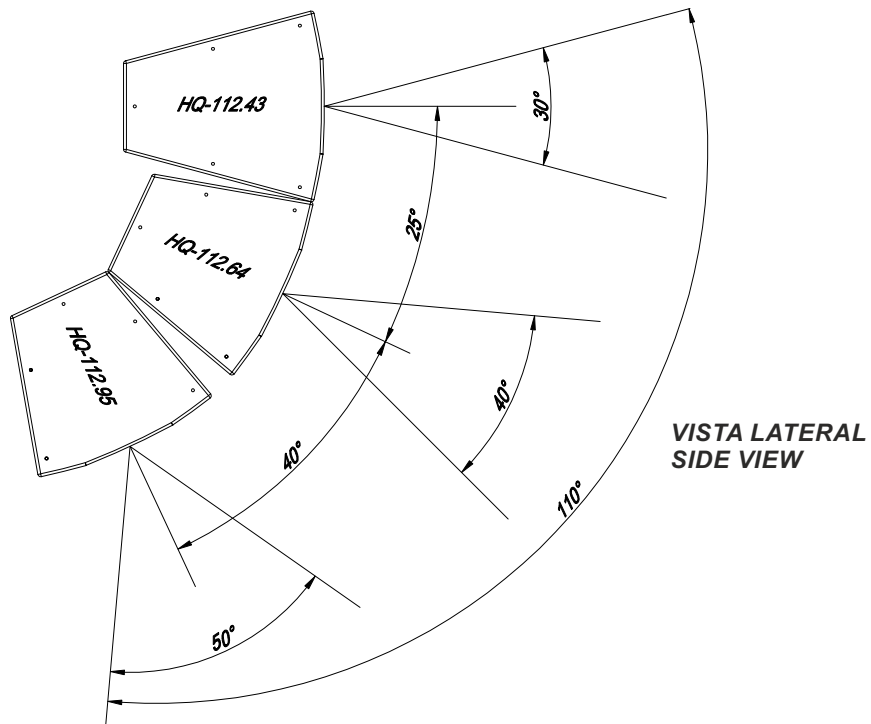

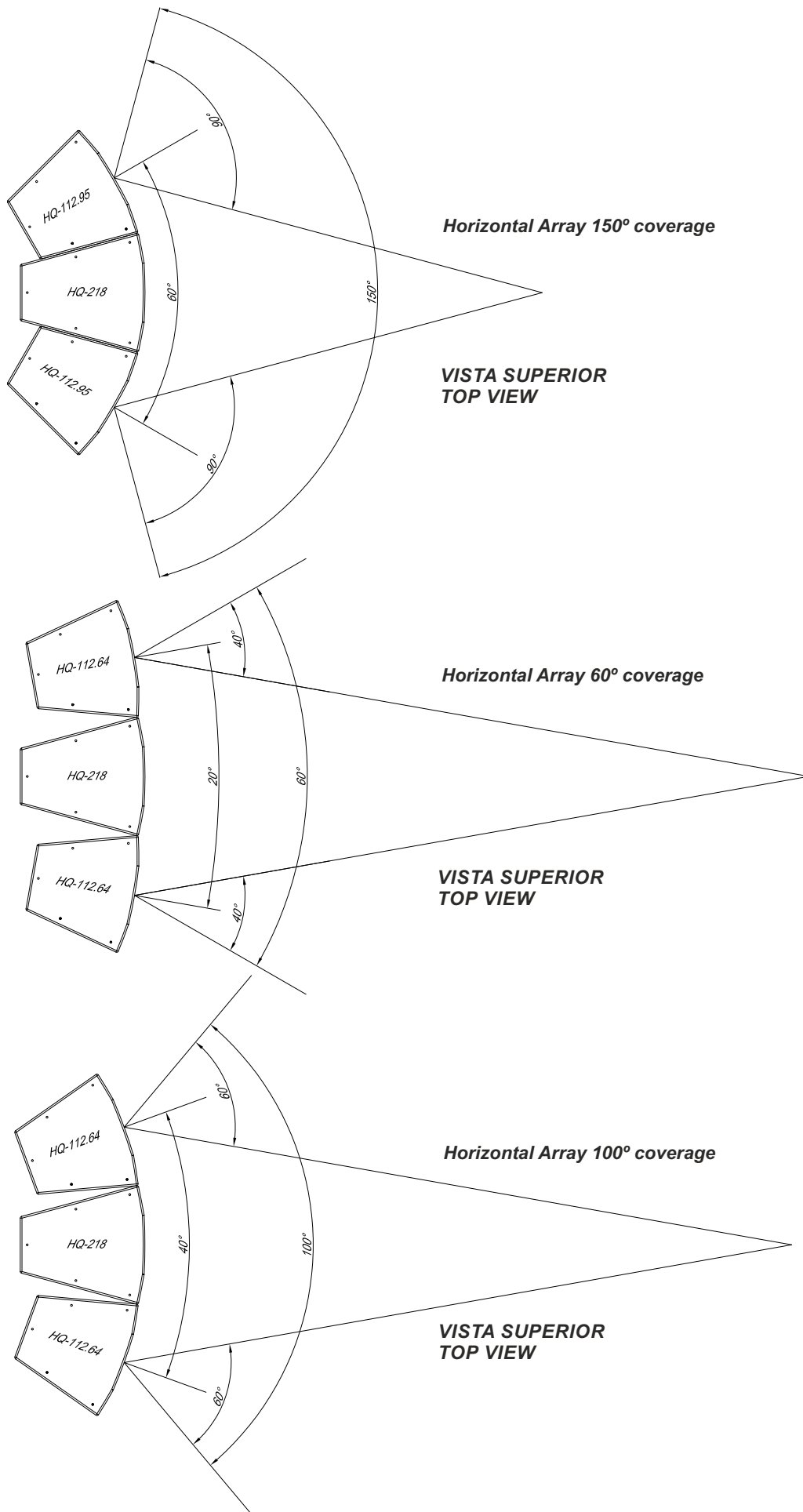

**VISTA SUPERIOR
TOP VIEW**

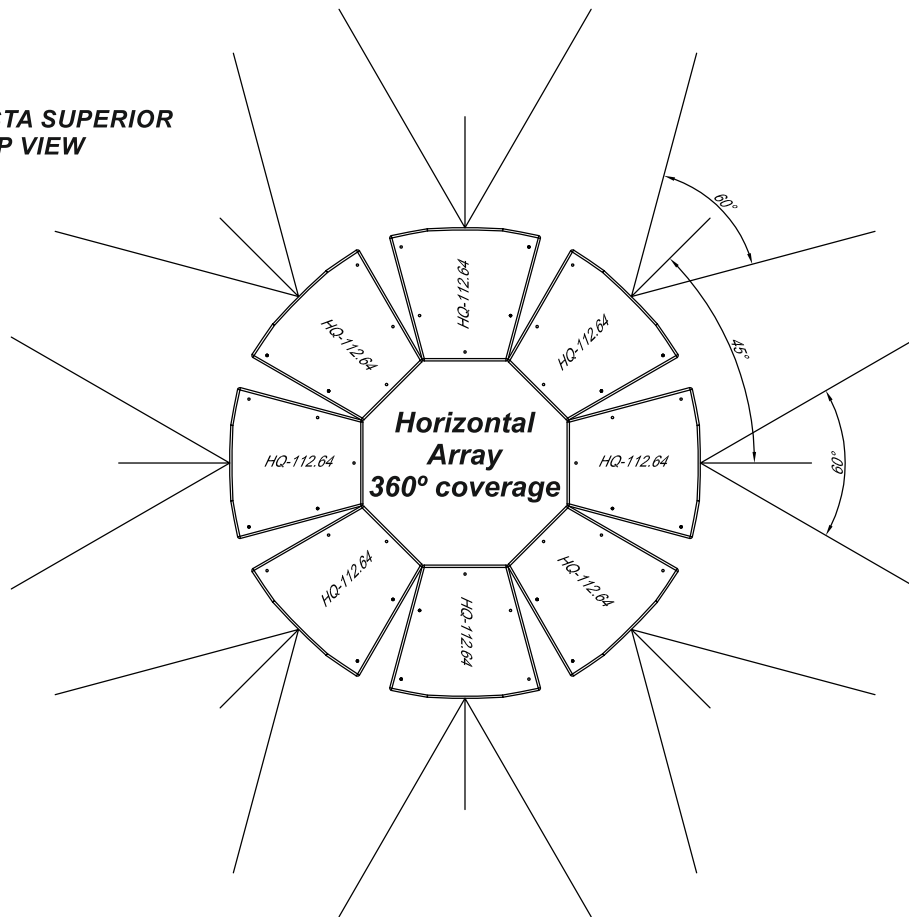

The **DAS HQ series**, as seen in these examples, allows more combinations to achieve the desired coverage in each installation. We have collected only the most indicative examples, given the infinite possibilities. On our website, you can find the "gll" files for *Ease Focus* software, with which you can simulate the acoustic performance of a given configuration of devices. For instance:

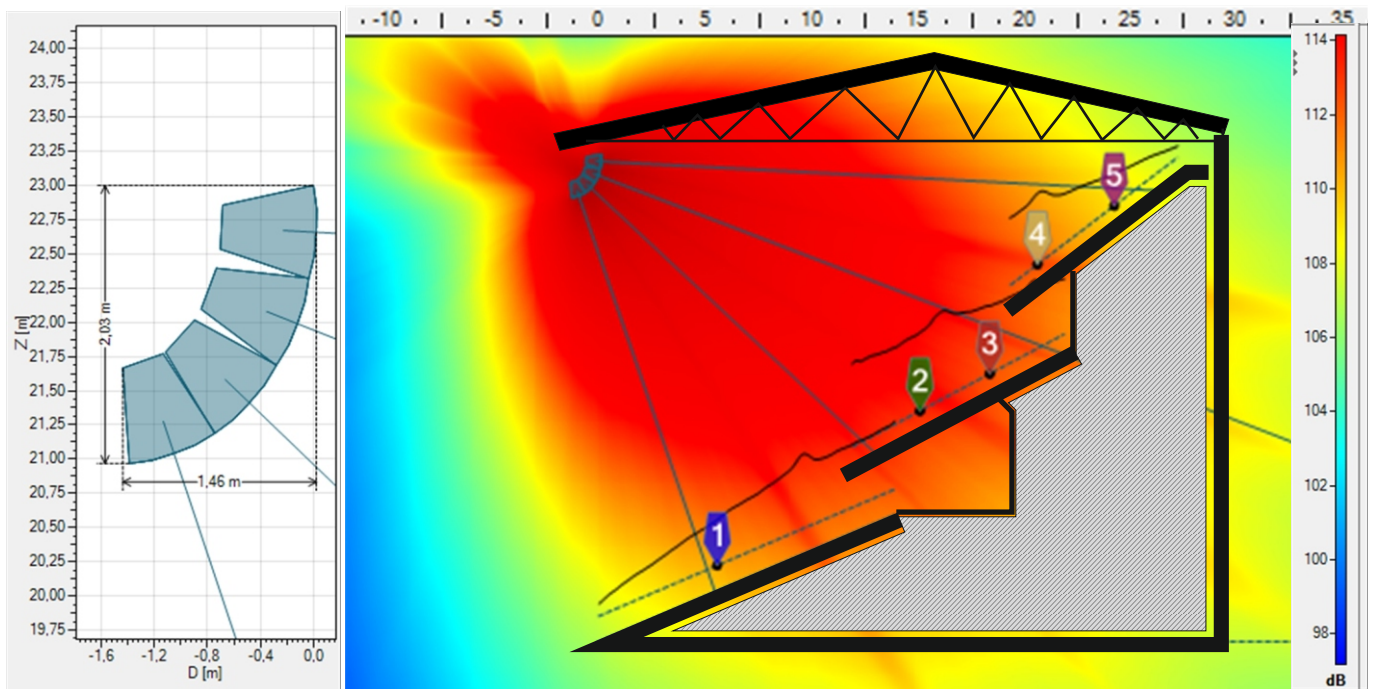

Example: HQ-212.XX with custom AX

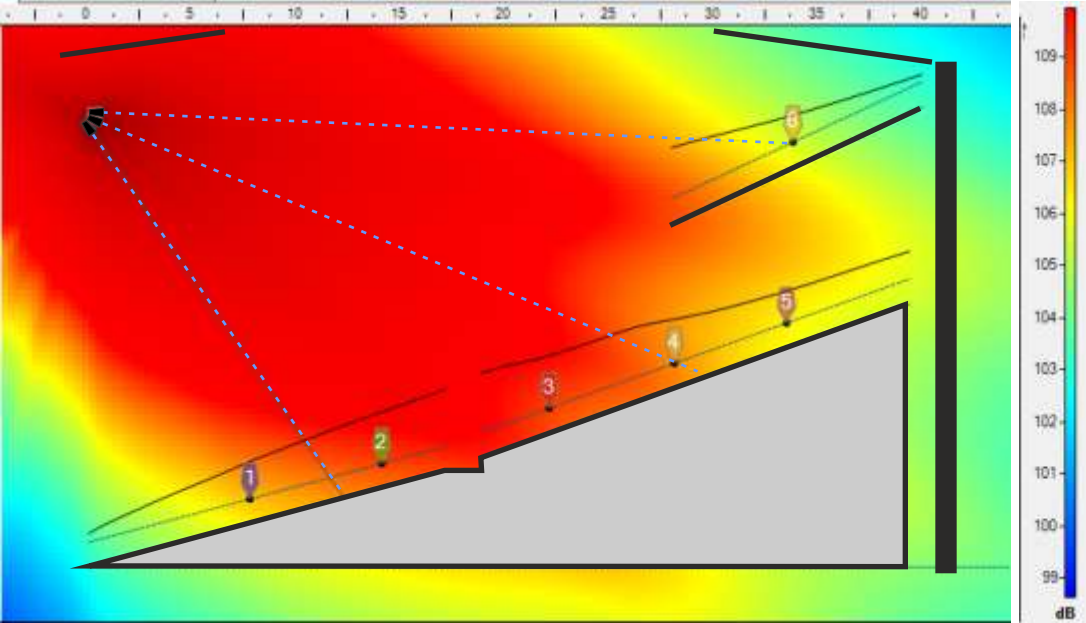
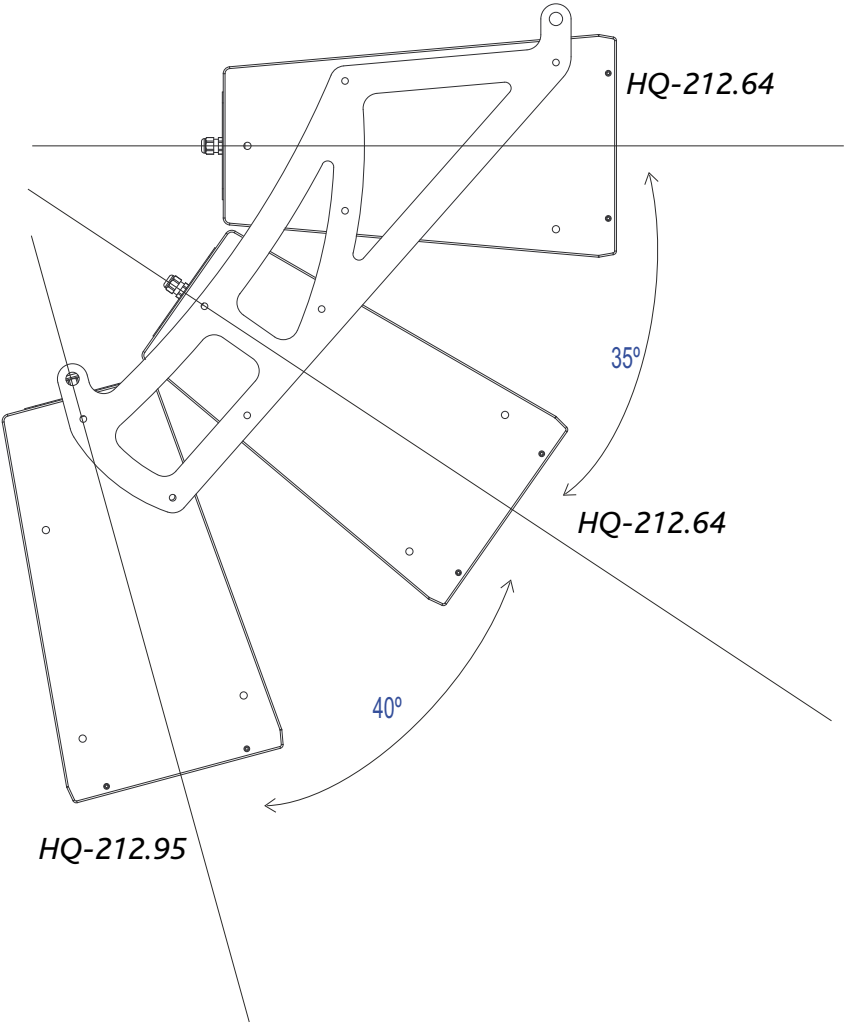

ACCESSORIES

To perform any operations related to flying the system, read the present document first, and act on the warnings and advice given.

The goal is to allow the user to become familiar with the mechanical elements required to fly the acoustic system, as well as the safety measures to be taken during set-up and teardown.

Only experienced installers with adequate knowledge of the equipment and local safety regulations should fly speaker boxes.

It is the user's responsibility to ensure that the systems to be flown (including flying accessories) comply with state and local regulations.

The working load limits in this manual are the results of tests by independent laboratories. It is the user's responsibility to stay within safe limits. It is the user's responsibility to follow and comply with safety factors, resistance values, periodical supervisions and warnings given in this manual.

Product improvement by means of research and development is on going at DAS Specifications are subject to change without notice.

It is common practice to apply 5:1 safety factors for enclosures and static elements.

For slings and elements exposed to material fatigue due to friction and load variation the following ratios must be met; 5:1 for steel cable slings, 4:1 for steel chain slings and 7:1 polyester slings.

Thus, an element with a breaking load limit of 1000 kg may be statically loaded with 200 kg (5:1 safety factor) and dynamically loaded with 142 Kg (7:1 safety factor).

The load capacity, of each lift motor, should be correspond to a safety factor of 10:1.

When flying a system, the working load must be lower than the resistance of each individual flying point in the enclosure, as well as each box.

Hanging hardware should be regularly inspected and suspect units replaced if in doubt.

This is important to avoid injury and absolutely no risks should be taken in this respect. It is highly recommended that you implement an inspection and maintenance program on flying elements, including reports to be filled out by the personnel that will carry out the inspections.

Local regulations may exist that, in case of accident, may require you to present evidence of inspection reports and corrective actions after defects were found.

Absolutely no risks should be taken with regards to public safety.

When flying enclosures from ceiling support structures, extreme care should be taken to assure the load bearing capabilities of the structures so that the installation is absolutely safe.

Do not fly enclosures from unsafe structures.

Consult a certified professional if needed.

All flying accessories that are not supplied by DAS Audio are the user's responsibility. Use at your own risk.

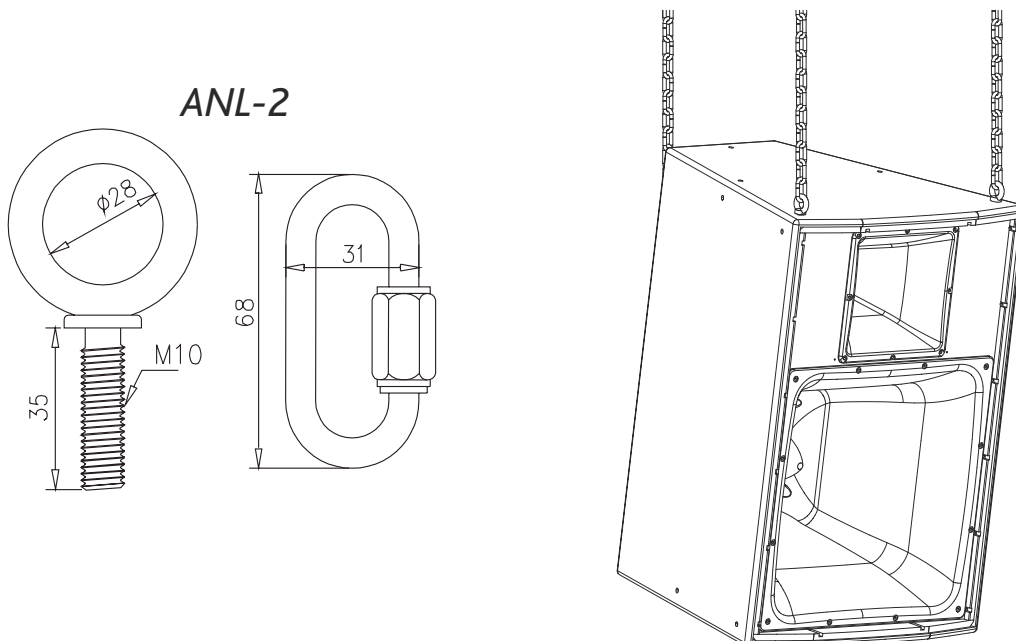

To hang the units, the Allen-head screws must be removed and replaced by M10 eyebolts on one side of the enclosure. Each rigging point has a 200 kg (440 lb) working load limit.

Then choose the slings or chains of required load resistance and length, bearing in mind that the length difference between the front and back slings or chains will determine the vertical orientation. Alternatively, the back bottom eyebolt points can be used to provide vertical orientation.

The *ANL-2* set is an optional set of four eyebolts and four carabiners. (Dimensions are in millimeters).

Each *ANL-2* eyebolt has a rated working load of 200 kg. (440 lb). Each *ANL-2* carabiner has a working load of 330 kg (726 lb). If using other hardware, make sure it is rated to handle the required load.

When using eyebolts it is important to bear in mind that the rated working load is only true for a load applied in the plane of the eye, and is significantly reduced for other angles. The drawing illustrates the concept.

The table shows the variation of the working load as a function of the load angle. In the case of the *ANL-2* eyebolt, this means that the 200 kg working load becomes 60 kg at 45 degrees. Do not use eyebolt flying if the load angle is higher than 45 degrees.

Note: As always, when we handle heavy loads, we should wear appropriate clothing and protective elements such as gloves, safety shoes, etc.

	0 Degrees	30 Degrees	45 Degrees	More than 45 Degrees
% Working load	100%	65%	30%	25%

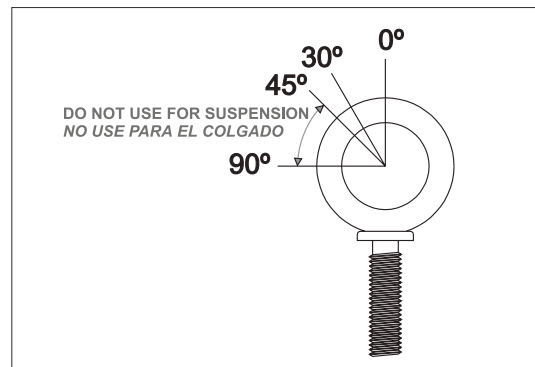

Next, you will see some examples, both horizontal and vertical array.

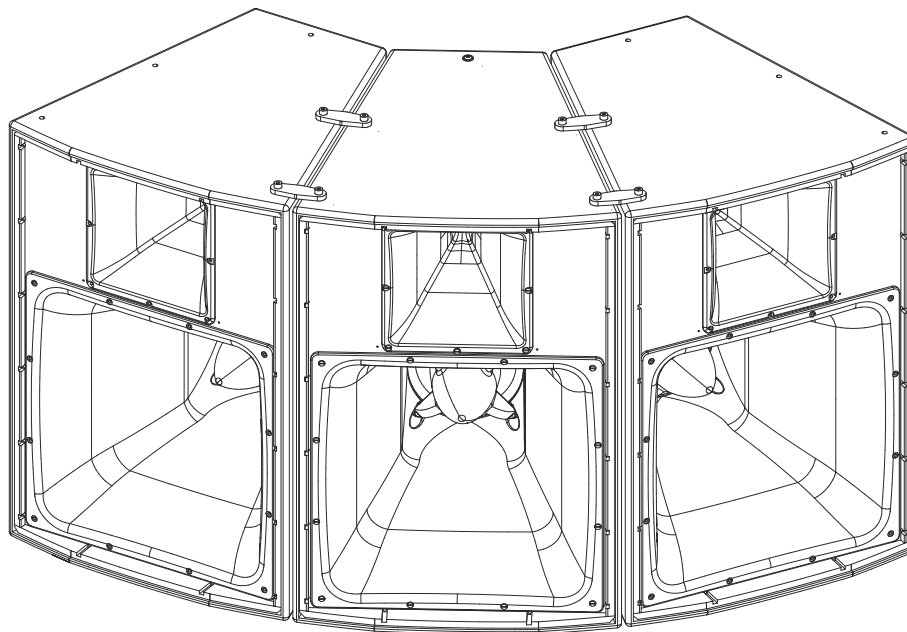

Horizontal array: 3x HQ-112.xx joined with AX-SF-3

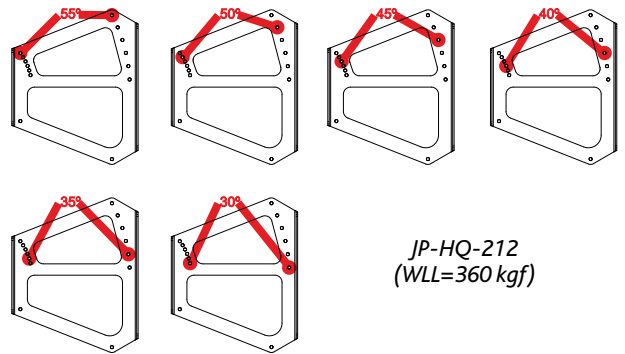
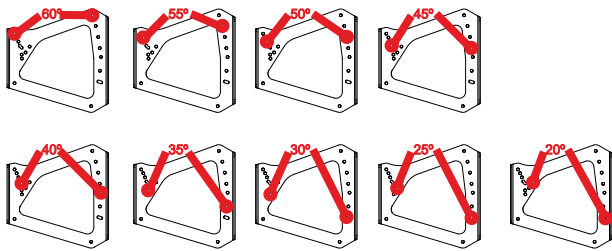
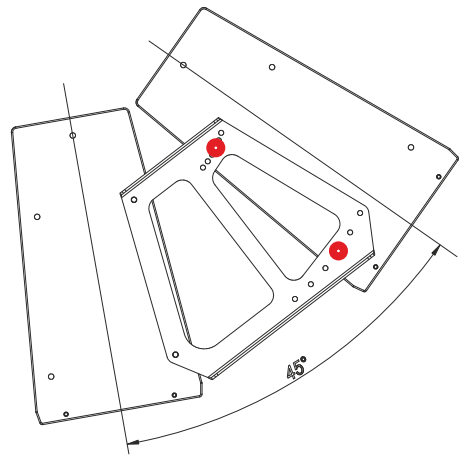
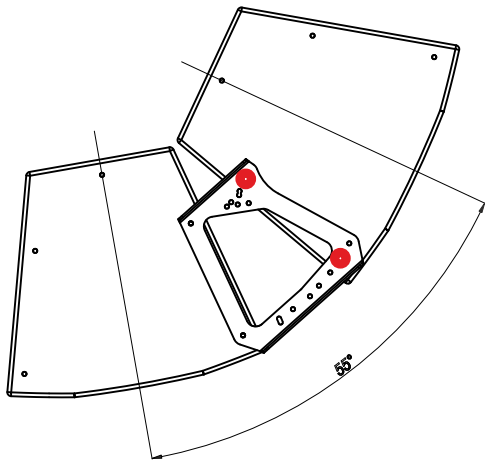

JP-HQ-112
(WLL=430 kgf)

JP-HQ-212
(WLL=360 kgf)

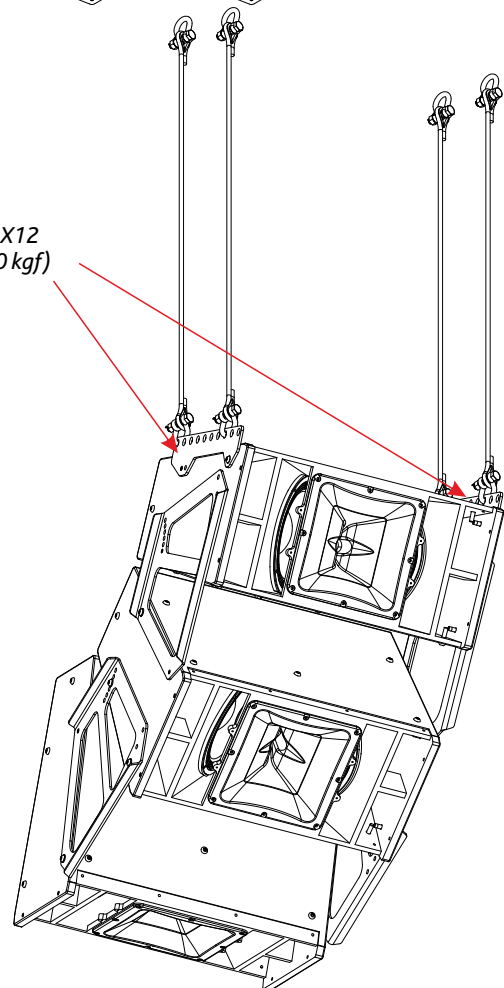
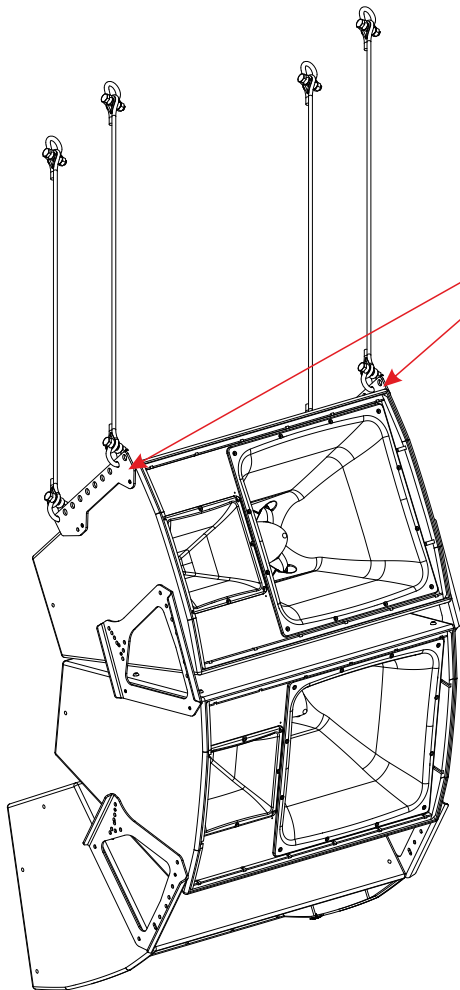

AX-HQ-X12
(WLL=450 kgf)

Vertical array: 3x HQ-112.xx

Vertical array: 3x HQ-112.xx + 1x HQ-218

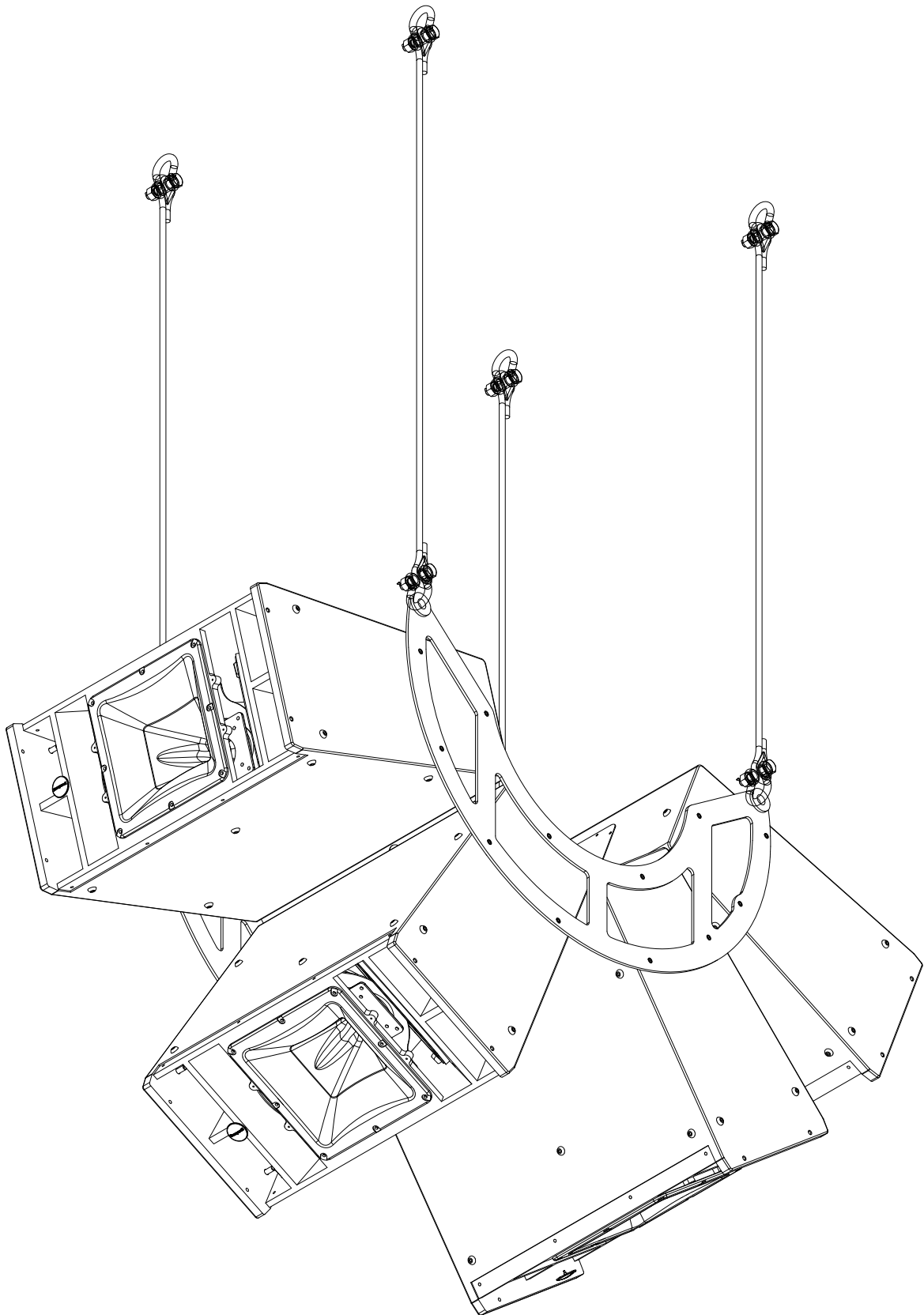

Vertical array: 4x HQ-212.xx with custom AX

ANNEX : Table for cable selection

This table shows the power loss in % and dB, for different cable lengths and sections shown. It is recommended that the losses do not exceed 30% in any case (around 3dB). Although it is recommended minimizing losses, the maximum acceptable losses are usually around 15% (approximately 1.4dB).

Longitud / Length		Calibre	Area	R	Perdida de potencia / Power Loss			
m	ft	AWG	mm2	Ohms	% @ 8 ohms	% @ 4 ohms	dB @ 8 ohms	dB @ 4 ohms
5	16,4	18	0,8	0,2250	2,74	5,33	-0,241	-0,475
		16	1,31	0,1374	1,69	3,32	-0,148	-0,293
		14	2,1	0,0857	1,06	2,10	-0,093	-0,184
		12	3,3	0,0545	0,68	1,35	-0,059	-0,118
		10	5,3	0,0340	0,42	0,84	-0,037	-0,073
		8	8,35	0,0216	0,27	0,54	-0,023	-0,047
10	33	18	0,8	0,4500	5,33	10,11	-0,475	-0,926
		16	1,31	0,2748	3,32	6,43	-0,293	-0,577
		14	2,1	0,1714	2,10	4,11	-0,184	-0,364
		12	3,3	0,1091	1,35	2,65	-0,118	-0,234
		10	5,3	0,0679	0,84	1,67	-0,073	-0,146
		8	8,35	0,0431	0,54	1,07	-0,047	-0,093
15	49	18	0,8	0,6750	7,78	14,44	-0,704	-1,354
		16	1,31	0,4122	4,90	9,34	-0,436	-0,852
		14	2,1	0,2571	3,11	6,04	-0,275	-0,541
		12	3,3	0,1636	2,00	3,93	-0,176	-0,348
		10	5,3	0,1019	1,26	2,48	-0,110	-0,218
		8	8,35	0,0647	0,80	1,59	-0,070	-0,139
25	82	18	0,8	1,1250	12,33	21,95	-1,143	-2,153
		16	1,31	0,6870	7,91	14,66	-0,716	-1,377
		14	2,1	0,4286	5,08	9,68	-0,453	-0,884
		12	3,3	0,2727	3,30	6,38	-0,291	-0,573
		10	5,3	0,1698	2,08	4,07	-0,182	-0,361
		8	8,35	0,1078	1,33	2,62	-0,116	-0,231
50	164	18	0,8	2,2500	21,95	36,00	-2,153	-3,876
		16	1,31	1,3740	14,66	25,57	-1,377	-2,565
		14	2,1	0,8571	9,68	17,65	-0,884	-1,686
		12	3,3	0,5455	6,38	12,00	-0,573	-1,110
		10	5,3	0,3396	4,07	7,83	-0,361	-0,708
		8	8,35	0,2156	2,62	5,11	-0,231	-0,456
75	246	18	0,8	3,3750	29,67	45,76	-3,057	-5,314
		16	1,31	2,0611	20,49	34,01	-1,991	-3,610
		14	2,1	1,2857	13,85	24,32	-1,295	-2,421
		12	3,3	0,8182	9,28	16,98	-0,846	-1,616
		10	5,3	0,5094	5,99	11,30	-0,536	-1,041
		8	8,35	0,3234	3,88	7,48	-0,344	-0,675
100	328	18	0,8	4,5000	36,00	52,94	-3,876	-6,547
		16	1,31	2,7481	25,57	40,72	-2,565	-4,542
		14	2,1	1,7143	17,65	30,00	-1,686	-3,098
		12	3,3	1,0909	12,00	21,43	-1,110	-2,095
		10	5,3	0,6792	7,83	14,52	-0,708	-1,362
		8	8,35	0,4311	5,11	9,73	-0,456	-0,889



www.dasaudio.com

UM_HQ_04_EN