



WLA-28X

QUICK START GUIDE

Congratulations on the purchase of your WLA-28X system. We take great pride in engineering and building every Wharfedale Pro product and wish to thank you for entrusting us with your audio.

From the time Gilbert Briggs built his first loudspeaker in 1932, to the present day, we have maintained the same standard of quality in components, workmanship and performance.

Please take the time to read this guide completely in order to get the most from your new line array.

Your full user manual can also be downloaded from www.wharfedalepro.com

IMPORTANT SAFETY INSTRUCTIONS

1. READ ALL INSTRUCTIONS - carefully and become familiar with the features and functions of these products before operating them.
2. RETAIN THESE INSTRUCTIONS - for future reference.
3. COMPLY WITH ALL WARNINGS - All warnings and instructions for this product should be adhered to.
4. USE WITH AMPLIFIERS - In order to avoid damage to drivers and other equipment, it is advisable to establish and follow a routine for powering up and powering down a sound system. With all system components connected, turn on source equipment (mixers, signal processors, record and playback units, etc.) BEFORE powering up amplifiers. Transient voltages from powering up source equipment can damage speakers if amplifiers are already turned on. Make sure that amplifier volumes are set to their minimum settings and power up any system amplifiers LAST. It is recommended that all system components be allowed to stabilize for several seconds before any source signals are introduced or level setting adjustments are made. Similarly, when shutting systems down, turn all amplifiers off first, before powering down any other system components.
5. CABLES - Do not use shielded or microphone cables for connection between amplifiers and speakers. Use only approved speaker cables with proper connectors.
6. CAUTION - Professional loudspeaker systems are capable of generating very high sound pressure levels. Use care with placement and operation to avoid exposure to excessive volume levels. Permanent hearing damage can result when operated to extreme levels.
7. SERVICE - There are no user serviceable parts inside this product. Users should not attempt to service this product. Warranty nullification could result if this is attempted.
3. RIGGING - SUSPENDING - MOUNTING - Rigging suspending or mounting of speaker systems can expose members of the public to serious health risks and even death.

UNDER NO CIRCUMSTANCES ATTEMPT TO RIG, SUSPEND OR OTHERWISE MOUNT THESE SPEAKERS UNLESS YOU ARE FULLY QUALIFIED AND CERTIFIED TO DO SO BY RELEVANT LOCAL, STATE AND NATIONAL AUTHORITIES. ALL RELEVANT SAFETY REGULATIONS MUST BE FOLLOWED. IF YOU ARE NOT PROPERLY QUALIFIED OR DO NOT KNOW OF PERTINENT REGULATIONS, CONSULT QUALIFIED PERSONNEL FOR ADVICE.

WHARFEDALE PRO LIMITED WARRANTY

Wharfedale Pro products are warranted of manufacturing or material defects for a period of one year from the original date of purchase. In the event of malfunction, contact your authorized Wharfedale Pro dealer or distributor for information.

*Be aware that warranty details may differ from country to country. Contact your dealer or distributor for information. These terms do not infringe your statutory rights.



WHARFEDALE PROFESSIONAL

IAG House, 13/14 Glebe Road, Huntingdon, Cambridgeshire, PE29 7DL, UK

www.wharfedalepro.com

Wharfedale Professional reserves the right to alter or improve specifications without notice.

All rights reserved © 2021 Wharfedale Pro. Wharfedale Pro is a member of the IAG Group.

SPECIFICATION

Model Name	WLA-28X
System Type	2 x 8" Two-way
Frequency Response (+/-3 dB)	65 Hz-20 KHz
Sensitivity (2.83 v / 1 m)	101 dB
Calculated Maximum SPL @1 m	133 dB
Nominal Coverage (H x V)	100°x10°
Power: Continuous / Programme / Peak	Passive: 400 W / 800 W / 1600 W Bi-amp LF: 400 W / 800 W / 1600 W Bi-amp HF: 90 W / 180 W / 360 W
Rated Impedance (Ω)	Passive: 16 Ω Bi-amp LF: 16 Ω ; Bi-amp HF: 16 Ω
HF Diaphragm Material	Titanium
HF Magnet Material	NdFeB
LF Magnet Material	Ferrite
LF Frame Material	Aluminium
HF Coil Size (inches/mm)	3.0" (75 mm)
LF Coil Size (inches/mm)	2.0" (51.6 mm)
Crossover Frequency	1.7 KHz
Cabinet Type	Trapezoid
Enclosure Material and finish	18 mm / 15 mm Plywood
Enclosure Colour	Black paint
Grille Material & Finish	1.5 mm Steel
Connectors	Neutrik NL4MP
Hardware	Integral side plate adjustable rigging 0°-10°
Cabinet Dimensions HxWxD(mm)	250 x 760 x 463.2 mm
Packed Dimensions HxWxD(mm)	320 x 830 x 534 mm
Net Weight (Kg)	29.5 Kg
Gross Weight (Kg)	32.0 Kg

OVERVIEW

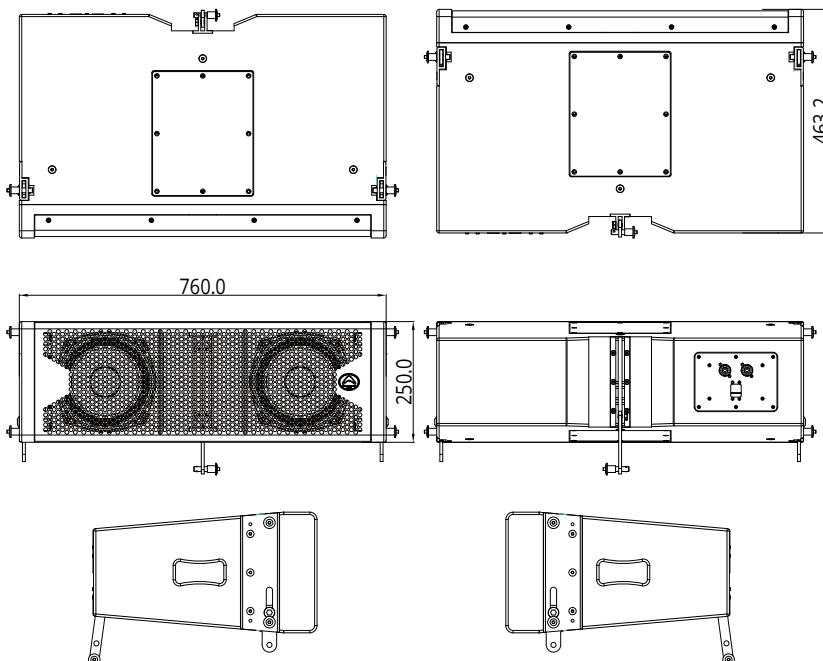

KEY FEATURES:

- Dual 8" Passive line array
- Re-defined HF compression driver
- System AES (Continuous) LF: 400 W HF: 90 W
- System Programme Power LF: 800 W HF: 180 W
- System Peak Power LF: 1600 W HF: 360 W
- Impedance 16 Ω
- 15 mm / 18 mm Plywood construction

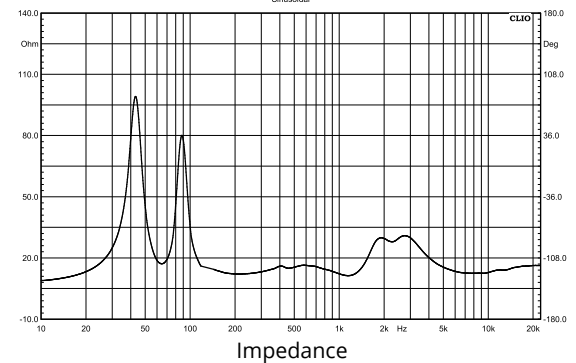
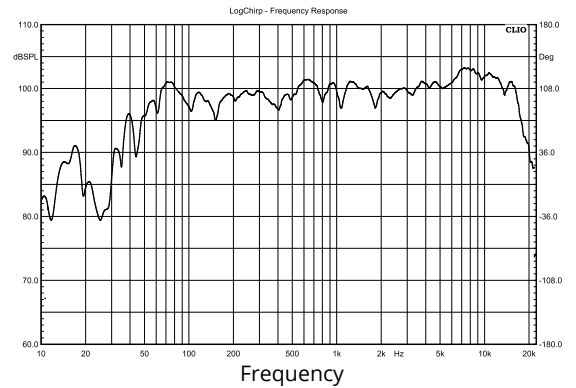

CROSSOVER BLOCK DIAGRAM

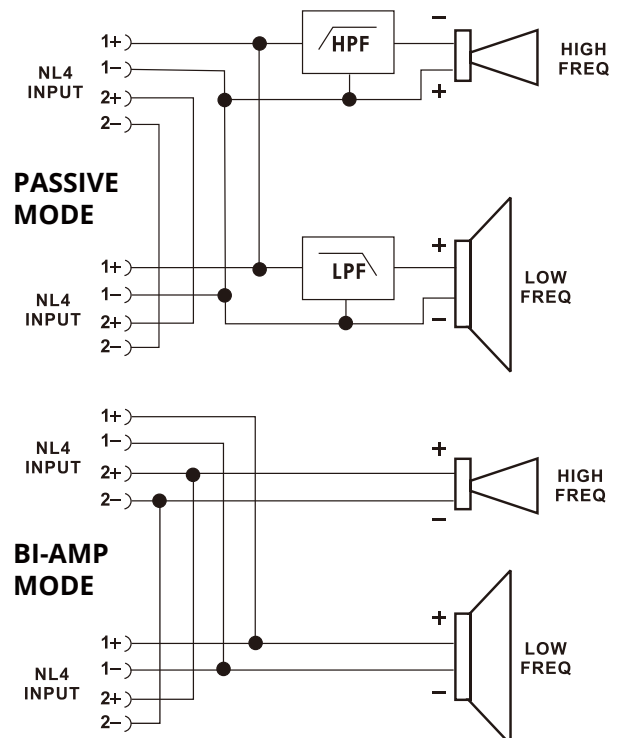

Wharfedale Pro also manufacture a wide range of power amplifiers and signal processors.
For recommended accessories, amplifiers and system diagrams please visit www.wharfedalepro.com